

Control Modes

- Indexer, Point-to-Point, PVT
- Camming, Gearing
- Position, Velocity, Torque

Command Interface

- CANopen over EtherCAT® (CoE)
- ±10V position/velocity/torque
- Master encoder (Gearing/Camming)
- ASCII via RS-232

Communications

- EtherCAT®
- RS-232

Feedback

Incremental

- Digital quad A/B encoder
- Aux. encoder / encoder out
- Analog sin/cos encoder
- Digital Halls
- Incremental A (Panasonic)

Absolute

- SSI,
- EnDat
- Absolute A (HD, Tamagawa, Panasonic, Sanyo Denki, Nikon)
- BiSS

I/O Digital

- 8 inputs, 3 outputs

Dimensions: mm [in]

- 196 x 99 x 31 [7.7 x 3.9 x 1.2]



Model	I _p	I _c	V _{dc}
AEP-055-18	18	6	55
AEP-090-09	9	3	90
AEP-090-18	18	6	90
AEP-090-36	36	12	90
AEP-180-09	9	3	180
AEP-180-18	18	6	180

DESCRIPTION

Accelnet EtherCAT® is a high-performance, DC powered drive for position, velocity, and torque control of brushless and brush motors via EtherCAT®, an Ethernet-based fieldbus. Drive commissioning is fast and simple using CME 2™ software operating under Windows® and communicating with Accelnet EtherCAT® via RS-232.

Accelnet operates as an EtherCAT® slave using the CANopen over EtherCAT® (CoE) protocol of DSP-402 for motion control devices. Supported modes include: Profile Position-Velocity-Torque, Cyclic Synchronous Position-Velocity-Torque, Interpolated Position Mode (PVT), and Homing.

Feedback from both incremental and absolute encoders is supported. A multi-mode encoder port functions as an input or output depending on the drive's basic setup. As an input it takes feedback from a secondary encoder to create a dual-loop position control system or as a master encoder for driving a cam table. As an output, it buffers the digital encoder signals from the motor's digital encoder and eliminate split cables that would be needed to send the signals to both drive and control system.

There are six opto-isolated digital inputs in two groups. All are common-anode types that source current into current-sinking switches in the controller. Inputs [IN1~4] are 24 Vdc compatible and inputs [IN5~6] are 5 Vdc compatible. The active levels are programmable as are the functions. The drive Enable function is dedicated to [IN1]. A non-isolated high-speed input [IN7] and output [OUT3] are provided, as well as two opto-isolated Darlington outputs [OUT1,2]. In addition, a ±10 Vdc analog input is provided for interfacing to sensors.

Drive power is transformer-isolated DC from regulated or unregulated power supplies. An AuxHV input is provided for "keep-alive" operation permitting the drive power stage to be completely powered down without losing position information, or communications with the control system.

GENERAL SPECIFICATIONS

Test conditions: Load = Wye connected load: 2 mH + 2 Ω line-line. Ambient temperature = 25°C, +HV = HV_{max}

MODEL	AEP-055-18	AEP-090-09	AEP-090-18	AEP-090-36	AEP-180-09	AEP-180-18	
OUTPUT POWER							
Peak Current	18 (12.7)	9 (6.4)	18 (12.7)	36 (25.5)	9 (6.4)	18 (12.7)	Adc (Arms-sine), ±5%
Peak time	1	1	1	1	1	1	Sec
Continuous current	6 (4.2)	3 (2.1)	6 (4.2)	12 (8.5)	3 (2.1)	6 (4.2)	Adc (Arms-sine) per phase
Output resistance	0.075	0.075	0.075	0.036	0.075	0.075	Rout (Ω)
Maximum Output Voltage	Vout = HV*0.97 - Rout*Iout						
INPUT POWER							
HVmin~HVmax	+20 to +55	+20 to +90	+20 to +90	+20 to +90	+20 to +180	+20 to +180	Vdc Transformer-isolated
Ipeak	20	10	20	40	10	20	Adc (1 sec) peak
Icont	6.7	3.3	6.7	13.3	3.3	6.7	Adc continuous
Aux HV	+20 to +HV Vdc @ 500 mAdc maximum, 2.5 W						
PWM OUTPUTS							
Type	3-phase MOSFET inverter, 16 kHz center-weighted PWM, space-vector modulation						
PWM ripple frequency	32 kHz						
CONTROL MODES							
CANopen over Ethernet (CoE): Profile Position, Profile Velocity, & Profile Torque, Interpolated Position (PVT), Homing Cyclic Synchronous Position/Velocity/Torque							
Analog ±10 Vdc, camming, internal indexer and function generator							
COMMAND INPUTS							
Type	EtherCAT®, galvanically isolated from drive circuits						
Connectors	Dual RJ-45 receptacles, 8-position						
Signals & format	TX+, TX-, RX+, RX-; 100BaseTX						
Data protocol	CANopen Device Profile DSP-402 over EtherCAT® (CoE)						
Address Selection	Dual 16-position rotary switches (0x01~0xFF or 1~255), or position in chain, or via software						
Analog	±10 Vdc, torque/velocity/position control						
Camming	Quad A/B digital encoder						
DIGITAL CONTROL							
Digital Control Loops	Current, velocity, position. 100% digital loop control						
Sampling rate (time)	Current loop: 16 kHz (62.5 μs), Velocity & position loops: 4 kHz (250 μs)						
Commutation	Sinusoidal, field-oriented control for brushless motors						
Modulation	Center-weighted PWM with space-vector modulation						
Bandwidths	Current loop: 2.5 kHz typical, bandwidth will vary with tuning & load inductance						
HV Compensation	Changes in bus voltage do not affect bandwidth						
Minimum load inductance	200 μH line-line						
DIGITAL INPUTS							
Number	8						
[IN1~4]	Common-anode opto-coupler: +24 Vdc to [COMMA], -7 mA per input into ground-active controllers						
[IN5~6]	Common-anode opto-coupler: +5 Vdc to [COMMB], -13 mA per input into ground-active controllers						
[IN7]	Non-isolated high-speed CMOS Schmitt trigger with 10 kΩ pull-up to +5 Vdc, 100 ns RC filter						
[IN8]	Motemp, input for motor temperature switch, 4.99 kΩ pull-up to +5 Vdc, 33 μs RC filter						
Functions	[IN2~8] are programmable, [IN1] is dedicated for drive Enable function						
DIGITAL OUTPUTS							
Number	3						
[OUT1~2]	Opto-isolated NPN Darlington with collector/emitter connections for each output						
Ratings	100 mAdc max, +30 Vdc max. Functions programmable						
Snubber	36 V Zener diode included for driving inductive loads						
[OUT3]	Non-isolated high-speed HS: CMOS UHS buffer, ±20 mA source/sink, +5 Vdc max						
MULTI-MODE ENCODER PORT							
As Secondary Encoder Input	Digital quadrature encoder (A, /A, B, /B, X, /X) 20M counts/sec, post-quadrature (5M lines/sec), MAX3096 line receiver						
As Buffered Encoder Output	Buffered signals from digital quad A/B/X primary encoder. 20M counts/sec, post-quadrature (5M lines/sec) A, /A, B, /B, X, /X, signals from MAX3042 differential line driver						
Secondary encoder power	+5 Vdc ±2% @ 400 mAdc max, current limited to 750 mAdc @ +1 Vdc if output overloaded (J4-22)						
FEEDBACK							
<i>Incremental:</i>							
Digital Incremental Encoder	Quadrature signals, (A, /A, B, /B, X, /X), differential (X, /X Index signals not required) 5 MHz maximum line frequency (20 M counts/sec) 26LS32 differential line receiver with 121 Ω terminating resistor between complementary inputs						
Analog Incremental Encoder	Sin/cos format (sin+, sin-, cos+, cos-), differential, 1 Vpeak-peak, ServoTube motor compatible						
<i>Absolute:</i>							
SSI	Clock (X, /X), Data (S, /S) signals						
EnDAT	Clock (X, /X), Data (S, /S), sin/cos (sin+, sin-, cos+, cos-) signals						
Absolute A	SD+, SD- (S, /S) signals						
BISS	MA+, MA- (X, /X), SL+, SL- (S, /S) signals						
Encoder power	+5 Vdc ±2% @ 400 mAdc max, current limited to 750 mAdc @ +1 Vdc if output overloaded (J3-3)						

RS-232 PORT

Signals	RxD, TxD, Gnd in 6-position, 4-contact RJ-11 style modular connector.
Mode	Full-duplex, DTE serial port for drive setup and control, 9,600 to 115,200 Baud
Protocol	ASCII or Binary format

MOTOR CONNECTIONS

Phase U, V, W	PWM outputs to 3-phase ungrounded Wye or delta connected brushless motors, or DC brush motors
Hall U, V, W	Digital Hall signals, single-ended
Digital Incremental Encoder	Quadrature signals, (A, /A, B, /B, X, /X), differential (X, /X Index signals not required) 5 MHz maximum line frequency (20 M counts/sec) 26LS32 differential line receiver with 121 Ω terminating resistor between complementary inputs
Analog Incremental Encoder	Sin/cos format (sin+, sin-, cos+, cos-), differential, 1 V _{peak-peak} X or S input may be firmware configured to latch position or time
Heidenhain EnDat 2.1, 2.2	Serial data and clock signals (DATA, /DATA, CLK, /CLK), differential; optionally sin/cos signals
Heidenhain EnDat 2.1,2.2, SSI	Serial data and clock signals (DATA, /DATA, CLK, /CLK), differential
BISS	MA+, MA-, SL+, SL-
Nikon A	SD+, SD-
Hall & encoder power (J3-3)	+5 Vdc ±2% @ 400 mAdc max, current limited to 750 mAdc @ +1 Vdc if output overloaded
Motemp [IN8]	Motor overtemperature switch input. Active level programmable, 4.99 kΩ pull-up to +5 Vdc Programmable to disable drive when motor over-temperature condition occurs
Brake	[OUT1~2] programmable for motor brake function and have flyback diode for inductive load

STATUS INDICATORS

Amp Status	Bicolor LED, drive status indicated by color, and blinking or non-blinking condition
EtherCAT® Status	Yellow & green LED on A & B ports, status of EtherCAT® bus indicated by color and blink codes to EtherCAT® Indicator Specification V0.91 Green LED: ON = Good Link, Blinking = Activity, OFF = No Link Yellow LED: ON for Full-Duplex, OFF for Half-Duplex

PROTECTIONS

HV Overvoltage	+HV > HV _{max}	Drive outputs turn off until +HV < HV _{max} (See Input Power for HV _{max})
HV Undervoltage	+HV < +20 Vdc	Drive outputs turn off until +HV > +20 Vdc
Drive over temperature	Heat plate > 70°C.	Drive outputs turn off
Short circuits	Output to output, output to ground, internal PWM bridge faults	
I ² T Current limiting	Programmable: continuous current, peak current, peak time	
Motor over temperature	Digital inputs programmable to detect motor temperature switch	
Feedback Loss	Inadequate analog encoder amplitude or missing incremental encoder signals	

MECHANICAL & ENVIRONMENTAL

Size	7.73 in (196.3 mm) X 3.90 in (99.1 mm) X 1.17 in (29.7 mm)
Weight	1.0 lb (0.45 kg)
Ambient temperature	0 to +45°C operating, -40 to +85°C storage
Humidity	0 to 95%, non-condensing
Vibration	2 g peak, 10~500 Hz (sine), IEC60068-2-6
Shock	10 g, 10 ms, half-sine pulse, IEC60068-2-27
Contaminants	Pollution degree 2
Environment	IEC68-2: 1990
Cooling	Heat sink and/or forced air cooling required for continuous power output

AGENCY STANDARDS CONFORMANCE

In accordance with EC Directive 2004/108/EC (EMC Directive)

EN 55011: 2007	CISPR 11:2003/A2:2006 Industrial, Scientific, and Medical (ISM) Radio Frequency Equipment – Electromagnetic Disturbance Characteristics – Limits and Methods of Measurement Group 1, Class A
EN 61000-6-1: 2007	Electromagnetic Compatibility (EMC) – Part 6-1: Generic Standards – Immunity for residential, Commercial and Light-industrial Environments

In accordance with EC Directive 2006/95/EC (Low Voltage Directive)

IEC 61010-1:2001	Safety Requirements for Electrical Equipment for Measurement, Control and Laboratory Use
------------------	--

Underwriters Laboratory Standards

UL 61010-1, 2nd Ed.: 2004	Safety Requirements for Electrical Equipment for Measurement, Control and Laboratory Use
UL File Number E249894	

ETHERCAT COMMUNICATIONS

EtherCAT® is the open, real-time Ethernet network developed by Beckhoff based on the widely used 100BASE-TX cabling system. EtherCAT® enables high-speed control of multiple axes while maintaining tight synchronization of clocks in the nodes. Data protocol is CANopen over EtherCAT® (CoE) based on DSP-402 for motion control devices.

ETHERCAT® CONNECTIONS

Dual RJ-45 sockets accept standard Ethernet cables. The IN port connects to a master, or to the OUT port of a device that is 'up-stream', between the Accelnet and the master. The OUT port connects to 'downstream' nodes. If Accelnet is the last node on a network, only the IN port is used. No terminator is required on the OUT port.

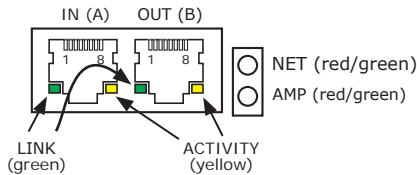

ETHERCAT® LEDS (ON RJ-45 CONNECTORS)

Green and yellow LEDs indicate the state of the EtherCAT® interface:

Green is the "Link" indicator: Yellow is the "Activity" indicator:
 On = Good Link On = Activity
 Off = No Link Blinking = No Activity

J6: EtherCAT® PORTS

RJ-45 receptacles,
8 position, 4 contact

PIN	SIGNAL
1	TX+
2	TX-
3	RX+
6	RX-

NET STATUS LED

A bi-color LED indicates the state of the EtherCAT® network.

Green and red colors alternate, and each color has a separate meaning:

Green is the "RUN" or EtherCAT® State Machine: Red is the "ERR" indicator:
 Off = INIT state Blinking = Invalid configuration
 Blinking = PRE-OPERATIONAL Single Flash = Unsolicited state change
 Single Flash = SAFE-OPERATIONAL Double Flash = Application watchdog timeout
 On = OPERATIONAL

AMP STATUS LED

A bi-color LED gives the state of the Accelnet drive.

Colors do not alternate, and can be solid ON or blinking:

Green/Solid = Drive OK and enabled. Will run in response to reference inputs or EtherCAT® commands.
 Green/Slow-Blinking = Drive OK but NOT-enabled. Will run when enabled.
 Green/Fast-Blinking = Positive or Negative limit switch active.
 Drive will only move in direction not inhibited by limit switch.
 Red/Solid = Transient fault condition. Drive will resume operation when fault is removed.
 Red/Blinking = Latching fault. Operation will not resume until drive is Reset.

EtherCAT® ADDRESS (STATION ALIAS)

In an EtherCAT® network, slaves are automatically assigned addresses based on their position in the bus. But when the device must have a positive identification that is independent of cabling, a Station Alias is needed. In the AEP, this is provided by two 16-position rotary switches with hexadecimal encoding. These can set the address of the drive from 0x01~0xFF (1~255 decimal). The chart shows the decimal values of the hex settings of each switch.

Example 1: Find the switch settings for decimal address 107:

- 1) Find the highest number under S1 that is less than 107 and set S1 to the hex value in the same row: 96 < 107 and 112 > 107, so S1 = 96 = Hex 6
- 2) Subtract 96 from the desired address to get the decimal value of switch S2 and set S2 to the Hex value in the same row: S2 = (107 - 96) = 11 = Hex B

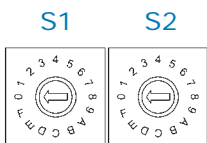

EtherCAT® Address Switch Decimal values

	S1	S2
HEX	DEC	
0	0	0
1	16	1
2	32	2
3	48	3
4	64	4
5	80	5
6	96	6
7	112	7
8	128	8
9	144	9
A	160	10
B	176	11
C	192	12
D	208	13
E	224	14
F	240	15

CME 2™ SOFTWARE

Drive setup is fast and easy using CME 2™ software. All of the operations needed to configure the drive are accessible through this powerful and intuitive program. Auto-phasing of brushless motor Hall sensors and phase wires eliminates “wire and try”. Connections are made once and CME 2™ does the rest thereafter. Encoder wire swapping to establish the direction of positive motion is eliminated. Motor data can be saved as .CCM files. Drive data is saved as .CCX files that contain all drive settings plus motor data. This eases system management as files can be cross-referenced to drives. Once an drive configuration has been completed systems can be replicated easily with the same setup and performance.

RS-232 COMMUNICATIONS

Accelnet EtherCAT® is configured via a three-wire, full-duplex DTE RS-232 port that operates from 9600 to 115,200 Baud. CME 2™ provides a graphic user interface (GUI) to set up all of Accelnet EtherCAT® features via a computer serial port. Connections to the Accelnet EtherCAT® RS-232 port are through J6, an RJ-11 style connector. Signal format is full-duplex, 3-wire, DTE using RxD, TxD, and Gnd. The Accelnet EtherCAT® Serial Cable Kit (SER-CK) contains a modular cable, and an adapter that connects to a 9-pin, Sub-D serial port connector (COM1, COM2, etc.) on PC's and compatibles.

J5: RS-232 PORT

RJ-11 receptacle,
6 position, 4 contact

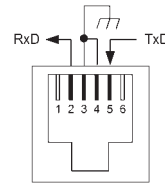

PIN	SIGNAL
2	RxD
3,4	Gnd
5	TxD

ANALOG INPUT

The differential configuration of the analog input has a ± 10 Vdc range and is useful for reading sensors or other voltage sources while rejecting noise on the signal ground that can occur due to power supply currents flowing in the wires to the drive. Shielded, twisted-pair wires are the best choice for connecting the input to the voltage source. One of the input terminals connects to the voltage source and the other should connect to signal ground at the voltage source. The effective range of the input can be scaled via a digital input, too. When the input is asserted the value of the commanded current or velocity command is divided by 8.

ANALOG INPUT [AI+/-]

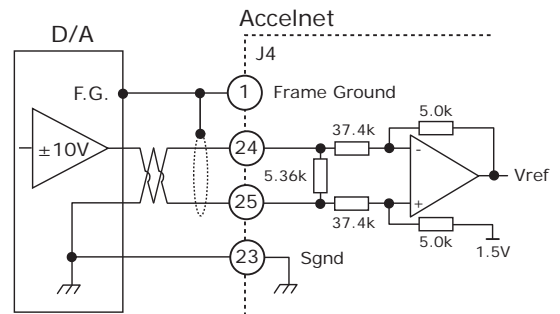

DIGITAL INPUTS

Inputs [IN1~6] are common-anode opto-isolators. With the [COMM_A] connected to +24 Vdc, the [IN1~4] signals can then be activated by NPN open-collector transistors on the controller. Inputs [IN5~6] take +5 V on the [COMM_B] terminal and so can be activated either by NPN open-collector, or CMOS/TTL outputs that can sink 13 mA. A high-speed input [IN7] is non-isolated. Programmable functions of the digital inputs include:

- Positive Limit switch
- Home switch
- Motion profile abort
- Motor overtemperature
- Indexer control
- Negative Limit switch
- Drive Reset
- Cam-table trigger
- Analog input ÷ 8
- Amp Enable

24 V Inputs GPI [IN1~4]

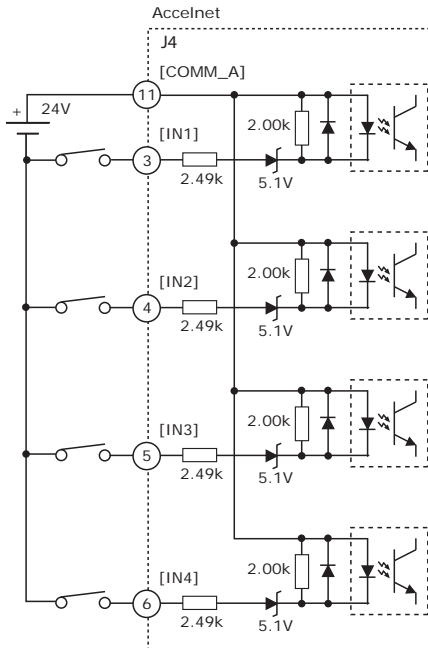

5 V Inputs GPI [IN5~6]

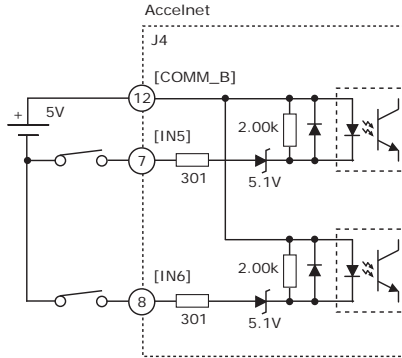

HS Input [IN7]

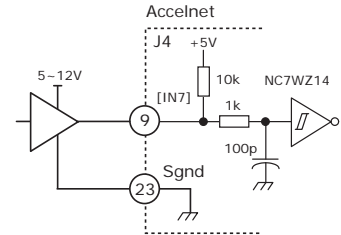

DIGITAL OUTPUTS

Two of these are Darlington opto-isolators with both terminals accessible. A Zener diode is included as a snubber for driving inductive loads. A third output is a high-speed CMOS buffer. Functions are programmable, as are the active levels (ON or OFF when True).

Programmable functions of the outputs include:

- Drive fault indicator
- Motor brake
- PWM sync
- Program controlled
- Custom trajectory status
- Custom position-triggered output
- Custom event

GP [OUT1,2]

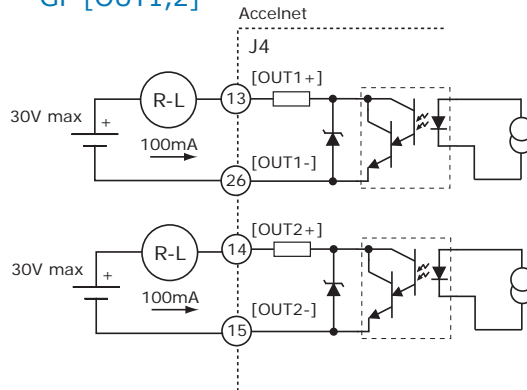

HS [OUT3]

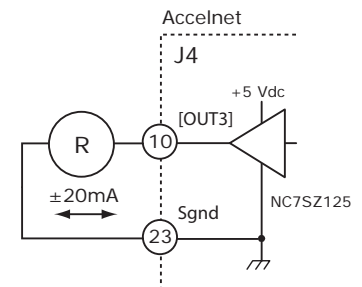

When configured as a Custom function, the output will go active when any of the events becomes true. When active, the output can be configured as on or off. The output can also be set to latching, or non-latching.

MOTOR CONNECTIONS

Motor connections consist of: phases, Halls, encoder, thermal sensor, and brake. The phase connections carry the drive output currents that drive the motor to produce motion. The Hall signals are three digital signals that give absolute position feedback within an electrical commutation cycle. The encoder signals give incremental position feedback and are used for velocity and position modes, as well as sinusoidal commutation. A thermal sensor that indicates motor overtemperature is used to shut down the drive to protect the motor. A brake can provide a fail-safe way to prevent movement of the motor when the drive is shut-down or disabled.

QUAD A/B ENCODER WITH FAULT PROTECTION

Encoders with differential line-driver outputs provide incremental position feedback via the A/B signals and the optional index signal (X) gives a once per revolution position mark. The MAX3097 receiver has differential inputs with fault protections for the following conditions:

Short-circuits line-line: This produces a near-zero voltage between A & /A which is below the differential fault threshold.

Open-circuit condition: The 121Ω terminator resistor will pull the inputs together if either side (or both) is open. This will produce the same fault condition as a short-circuit across the inputs.

Low differential voltage detection: This is possible with very long cable runs and a fault will occur if the differential input voltage is < 200mV.

±15kV ESD protection: The 3097E has protection against high-voltage discharges using the Human Body Model.

Extended common-mode range: A fault occurs if the input common-mode voltage is outside of the range of -10V to +13.2V

If encoder fault detection is selected (CME2 main page, Configure Faults block, Feedback Error) and an encoder with no index is used, then the X and /X inputs must be wired as shown below to prevent the unused index input from generating an error for *low differential voltage detection*.

A/B/X CONNECTIONS

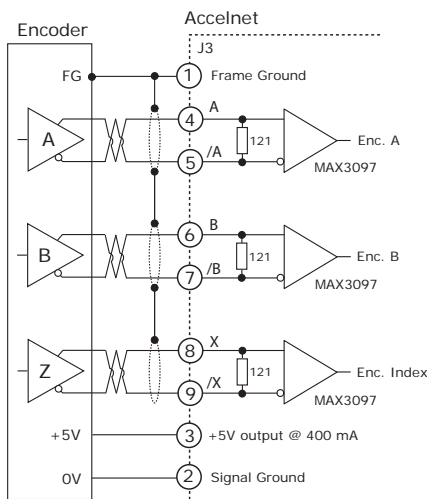

A/B CONNECTIONS (NO INDEX)

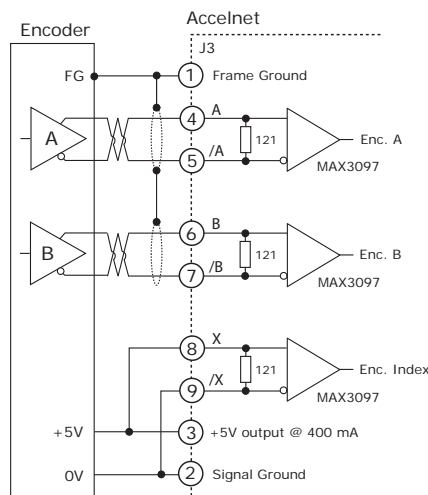

ANALOG SIN/COS INCREMENTAL ENCODER

The sin/cos inputs are differential with 121 Ω terminating resistors and accept 1 Vp-p signals in the format used by incremental encoders with analog outputs, or with [ServoTube](#) motors.

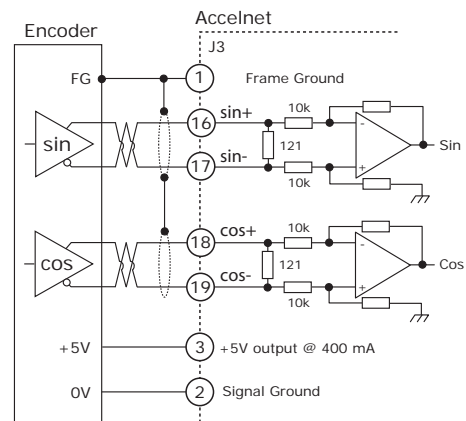

MOTOR CONNECTIONS (CONTINUED)

MULTI-MODE ENCODER PORT

This port consists of three differential input/output channels with functions programmable.

For dual-loop position-mode operation that employs a primary encoder on the motor, and a secondary encoder on the load, the port works as an input receiving the secondary encoder's quad A/B/X signals.

For stand-alone operation with an external motion controller, the signals from the digital encoder on the motor are buffered and made available at the control signal connector for transmission to the controller. This eliminates split-wired motor cables with dual connectors that take the encoder signals to both drive and controller.

INPUT FROM A SECONDARY ENCODER

A quad A/B/X digital encoder on the load provides feedback on the load position for a dual position loop configuration.

BUFFERED OUTPUTS FROM THE MOTOR ENCODER

Signals from a quad A/B/X digital encoder on the motor are buffered for transmission to an external motion controller.

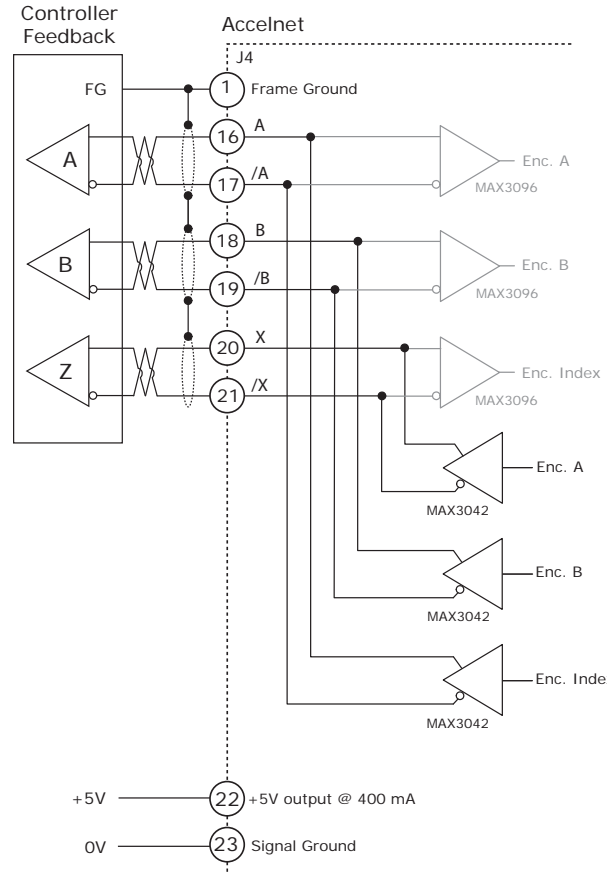
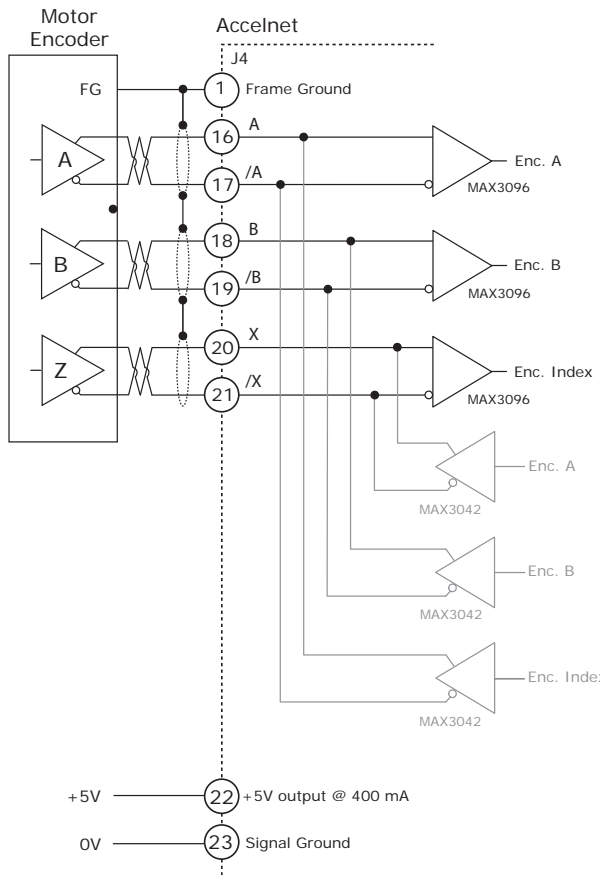

MOTOR CONNECTIONS (CONTINUED)

SSI ABSOLUTE ENCODER

The SSI (Synchronous Serial Interface) is an interface used to connect an absolute position encoder to a motion controller or control system. The Accelnet drive provides a train of clock signals in differential format (Clk, /Clk) to the encoder which initiates the transmission of the position data on the subsequent clock pulses. The polling of the encoder data occurs at the current loop frequency (16 kHz). The number of encoder data bits and counts per motor revolution are programmable. Data from the encoder in differential format (Dat, /Dat) MSB first. When the LSB goes high and a dwell time has elapsed, data is ready to be read again.

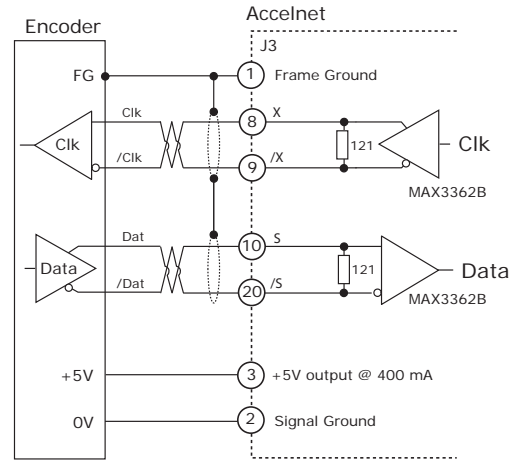

ENDAT ABSOLUTE ENCODER

The EnDat interface is a Heidenhain interface that is similar to SSI in the use of clock and data signals for synchronous digital, bidirectional data transfer. It also supports analog sin/cos channels from the same encoder. The number of position data bits is programmable. Use of sin/cos incremental signals is optional in the EnDat specification.

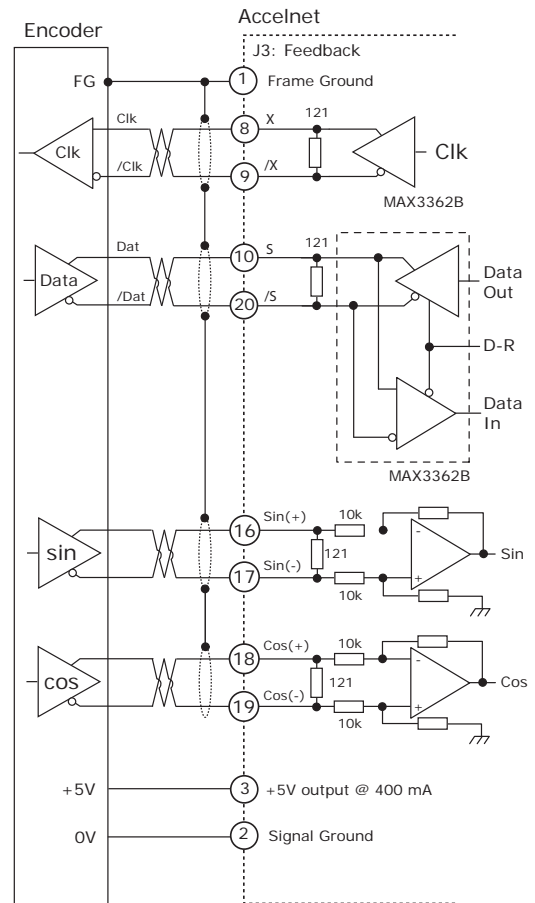

MOTOR CONNECTIONS (CONTINUED)

ABSOLUTE-A ENCODERS

The Absolute A interface is a bidirectional asynchronous serial type. Encoders of this type are used on motors manufactured by Panasonic, Sanyo Denki, and Tamagawa.

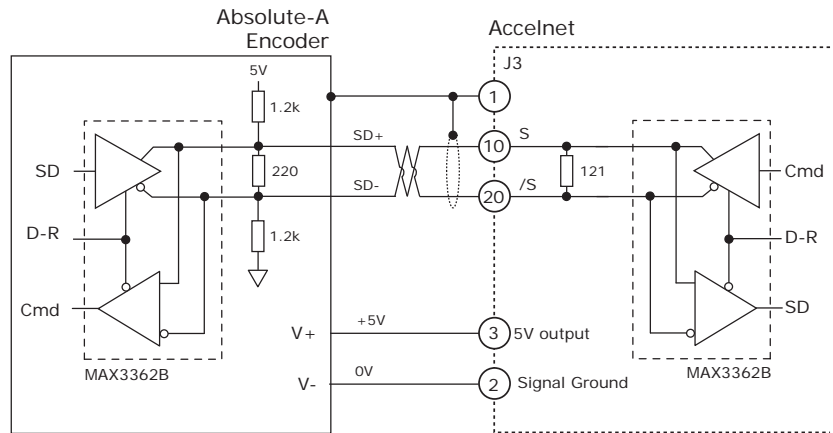

BiSS ABSOLUTE ENCODER

BiSS is an - Open Source - digital interface for sensors and actuators. BiSS refers to principles of well known industrial standards for Serial Synchronous Interfaces like SSI, AS-Interface® and Interbus® with additional options. The Accelnet supports the BiSS C (unidirectional) protocol.

- Serial Synchronous Data Communication
- Cyclic at high speed
- 2 unidirectional lines Clock and Data
- Line delay compensation for high speed data transfer
- Request for data generation at slaves
- Safety capable: CRC, Errors, Warnings
- Bus capability for multiple slaves & devices in a chain.

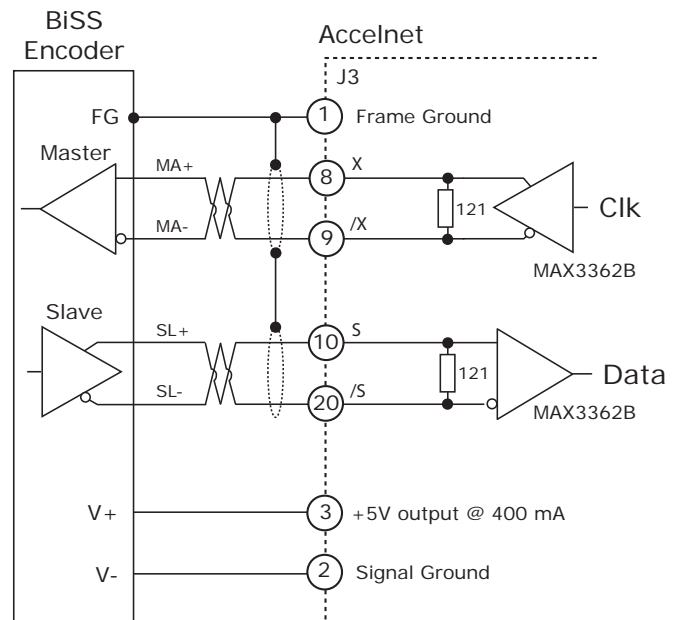

MOTOR CONNECTIONS (CONTINUED)

DIGITAL HALL SIGNALS

Hall signals are single-ended signals that provide absolute feedback within one electrical cycle of the motor. There are three of them (U, V, & W) and they may be sourced by magnetic sensors in the motor, or by encoders that have Hall tracks as part of the encoder disc. They typically operate at much lower frequencies than the motor encoder signals, and are used for commutation-initialization after startup, and for checking the motor phasing after the amplifier has switched to sinusoidal commutation.

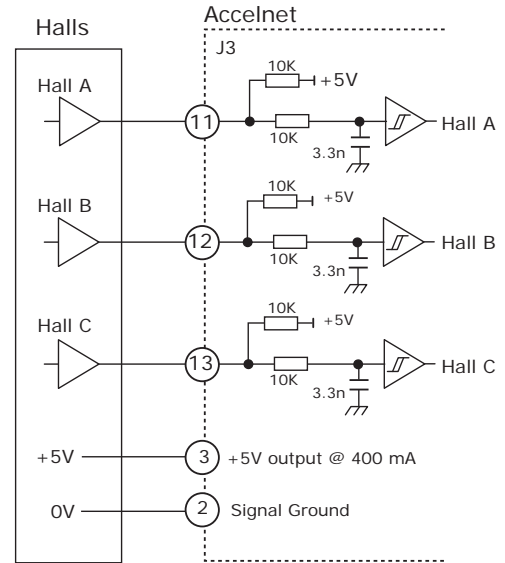

PHASE CONNECTIONS

The drive output is a three-phase PWM inverter that converts the DC bus voltage (+HV) into three sinusoidal voltage waveforms that drive the motor phase-coils. Cable should be sized for the continuous current rating of the drive. Motor cabling should use twisted, shielded conductors for CE compliance, and to minimize PWM noise coupling into other circuits. The motor cable shield should connect to motor frame and the drive HV ground terminal (J2-1) for best results. When driving a DC motor, the W output is unused and the motor connects between the U & V outputs.

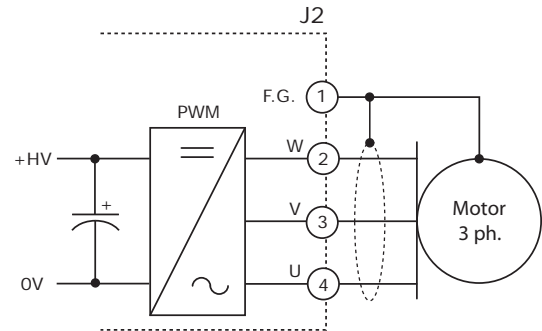

TEMPERATURE SENSOR

The MOTEMP input connects to J3-14 for use with a motor overtemperature switch. The switch or sensor must be grounded so that the input changes from LO to HI when the switch opens. The active level is programmable for use with switches that either open or close when the motor is overheating.

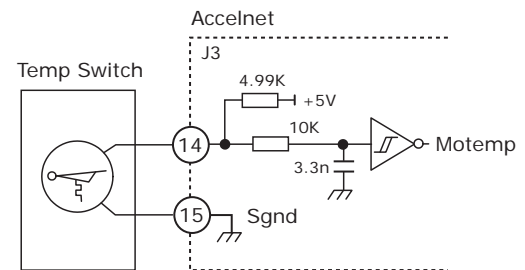

GROUNDING CONSIDERATIONS

Power and control circuits in *Accelnet EtherCAT®* share a common circuit-ground (HV_COM on J1-3, and Signal Ground on J3-2 & 15 and J4-2 & 23). Circuits that are referenced to Signal Ground are the analog Reference input, buffered encoder outputs, motor encoder and Hall signals, and the PWM outputs. For this reason, drive Signal Gnd terminals should connect to the users' control ground system so that signals between drive and controller are at the same common potential, and to minimize noise. The system ground should, in turn, connect to an earthing conductor at some point so that the whole system is referenced to "earth". The EtherCAT® ports are transformer-isolated from the drive circuits.

Because current flow through conductors produces voltage-drops across them, it is best to connect the drive HV Return to system earth, or circuit-common through the shortest path, and to leave the power-supply floating. In this way, the power supply (-) terminal connects to ground at the drive HV Return terminals, but the voltage drops across the cables will not appear at the drive ground, but at the power supply negative terminal where they will have less effect.

Motor phase currents are balanced, but currents can flow between the PWM outputs, and the motor cable shield. To minimize the effects of these currents on nearby circuits, the cable shield should connect to Frame Gnd (J2-4).

The drive case does not connect to any drive circuits. Connections to the case are provided on connectors J2-4, J3-1, J4-1. Cables to these connectors must be shielded for CE compliance, and the shields should connect to these terminals. When installed, the drive case should connect to the system chassis. This maximizes the shielding effect of the case, and provides a path to ground for noise currents that may occur in the cable shields.

Signals from controller to drive are referenced to +5 Vdc, and other power supplies in user equipment. These power supplies should also connect to system ground and earth at some point so that they are at same potential as the drive circuits.

The final configuration should embody three current-carrying loops. First, the power supply currents flowing into and out of the drive at the +HV and HV_COM pins on J1. Second the drive outputs driving currents into and out of the motor phases, and motor shield currents circulating between the U, V, and W outputs and Gnd. And, lastly, logic and signal currents connected to the drive control inputs and outputs.

For CE compliance and operator safety, the drive chassis should be earthed by using external tooth lock washers under the mounting screws. These will make contact with the aluminum chassis through the anodized finish to connect the chassis to the equipment frame ground.

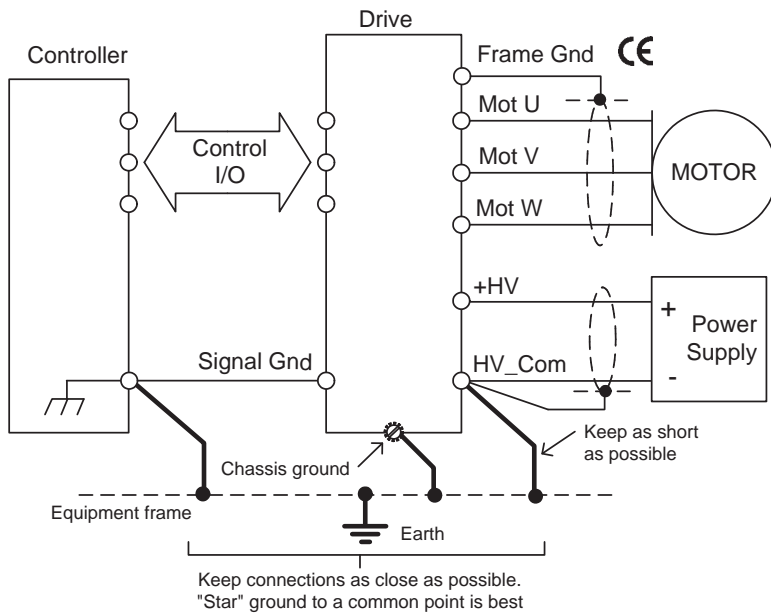

CE = Shielded cables required for CE compliance

POWER SUPPLIES

Accelnet EtherCAT® operates typically from transformer-isolated, unregulated DC power supplies. These should be sized such that the maximum output voltage under high-line and no-load conditions does not exceed the drives maximum voltage rating. Power supply rating depends on the power delivered to the load by the drive. In many cases, the continuous power output of the drive is considerably higher than the actual power required by an incremental motion application.

Operation from regulated switching power supplies is possible if a diode is placed between the power supply and drive to prevent regenerative energy from reaching the output of the supply. If this is done, there must be external capacitance between the diode and drive.



AUXILIARY HV POWER

Accelnet EtherCAT® has an input for AUX-HV. This is a voltage that can keep the drive communications and feedback circuits active when the PWM output stage has been disabled by removing the main +HV supply. This can occur during EMO (Emergency Off) conditions where the +HV supply must be removed from the drive and powered-down to ensure operator safety. The AUX-HV input operates from any DC voltage that is within the operating voltage range of the drive and powers the DC/DC converter that supplies operating voltages to the drive DSP and control circuits.

When the drive +HV voltage is greater than the AUX-HV voltage it will power the DC/DC converter. Under these conditions the AUX-HV input will draw no current.

MOUNTING & COOLING

Accelnet EtherCAT® has slots for mounting to panels at 0° or 90°. Cooling is by conduction from drive heatplate to mounting surface, or by convection to ambient.

A heatsink (optional) is required for the drive to deliver the rated continuous output current. Depending on the drive mounting and cooling means this may not be required.

CONNECTORS & SIGNALS

J4: CONTROL

J4 SIGNALS	PIN
Frame Ground	1
Signal Ground	2
Enable GPI [IN1]	3
GPI [IN2]	4
GPI [IN3]	5
GPI [IN4]	6
GPI [IN5]	7
GPI [IN6]	8
HS [IN7]	9
HS [OUT3]	10
[COMM_A]	11
[COMM_B]	12
GPI [OUT1+]	13

J3: FEEDBACK

J3 SIGNALS	PIN
Frame Ground	1
Signal Ground	2
+5 Vdc @ 400 mA Output	3
Encoder A	4
Encoder /A	5
Encoder B	6
Encoder /B	7
Encoder X	8
Encoder /X	9
Encoder S	10

J1: POWER

J1 SIGNALS	PIN
HV_COM	1
+HV	2
HV_AUX	3

J1 CABLE CONNECTOR:

3 position 5.08 mm Euro-Style plug
 Copley: 57-00465-000
 PCD: ELFP03210
 Ria: 31249103
 Weco: 121-A-111/03

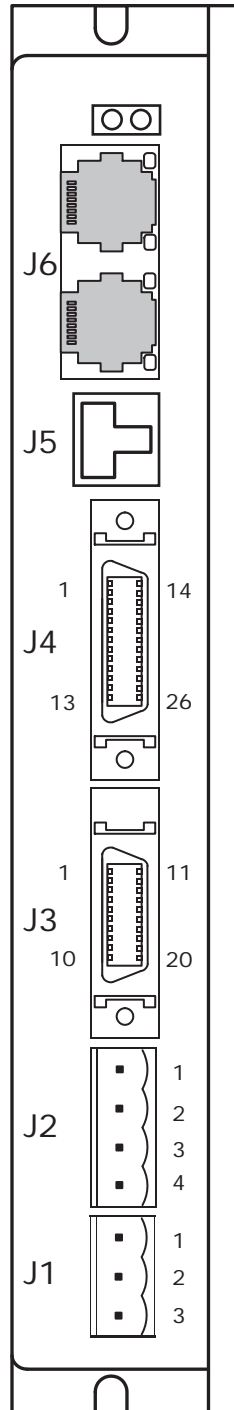

J4: CONTROL

PIN	J4 SIGNALS
14	GPI [OUT2+]
15	GPI [OUT2-]
16	Multi-mode Encoder A
17	Multi-mode Encoder /A
18	Multi-mode Encoder B
19	Multi-mode Encoder /B
20	Multi-mode Encoder X
21	Multi-mode Encoder /X
22	+5 Vdc @ 400 mA Output
23	Signal Ground
24	[AIN+]
25	[AIN-]
26	GPI [OUT1-]

J4 CABLE CONNECTOR:

Solder Cup, 26 position male, 1.27 mm pitch
 Cable: 26 conductor, shielded
 Standard with Snap locks
 3M: 10126-3000 VE connector
 3M: 10326-52F0-008 backshell
 Rugged with Screw-locks
 Molex: 54306-2619 connector
 Molex: 54331-0261 backshell

Note: Molded cable assemblies are available for J3 & J4. See p. 10 for cable colors.

J3: FEEDBACK

PIN	J3 SIGNALS
11	Hall U
12	Hall V
13	Hall W
14	[IN8] Motemp
15	Signal Ground
16	Analog Sin(+)
17	Analog Sin(-)
18	Analog Cos(+)
19	Analog Cos(-)
20	Encoder /S

J3 CABLE CONNECTOR:

Solder Cup, 20 position male, 1.27 mm pitch
 Cable: 20 conductor, shielded
 Standard with Snap locks
 3M: 10120-3000VE connector
 3M: 10320-52F0-008 backshell
 Rugged with Screw-locks
 Molex: 54306-2019 connector
 Molex: 54331-0201 backshell

J2: MOTOR

PIN	J2 SIGNALS
1	Frame Gnd
2	Motor U
3	Motor V
4	Motor W

J2 CABLE CONNECTOR:

4 position 5.08 mm Euro-Style plug
 Copley: 57-00466-000
 PCD: ELFP04210
 Ria: 31249104
 Weco: 121-A-111/04

ACCESSORY CABLE CONNECTIONS

SIGNAL CABLE (AEP-CC-10)

Cable assembly: CCC p/n 59-00785-000
Molded connector mates with drive J4 and has flying-lead terminations.

CONNECTOR (FRONT VIEW)

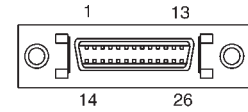

Signal	Pin	Color (Body/Stripe)	Pair		Color (Body/Stripe)	Pin	Signal
Frame Ground	1	Rev A & B: White/Tan Rev C: Brown	1a	8a	White/Violet	14	GIP [OUT2+]
Signal Ground	2	Rev A & B: Tan/White Rev C: Orange	1b	8b	Violet/White	15	GPI [OUT2-]
Enable [IN1]	3	White/Brown	2a	9a	White/Grey	16	Multi-Encoder A
GPI [IN2]	4	Brown/White	2b	9b	Gray/White	17	Multi-Encoder /A
GPI [IN3]	5	White/Pink	3a	10a	Tan/Brown	18	Multi-Encoder B
GPI [IN4]	6	Pink/White	3b	10b	Brown/Tan	19	Multi-Encoder /B
GPI [IN5]	7	White/Orange	4a	11a	Tan/Pink	20	Multi-Encoder X
GPI [IN6]	8	Orange/White	4b	11b	Pink/Tan	21	Multi-Encoder /X
HS [IN7]	9	White/Yellow	5a	12a	Tan/Orange	22	+5 Vdc @ 400 mA
HS [OUT3]	10	Yellow/White	5b	12b	Orange/Tan	23	Signal Ground
[COMM_A]	11	White/Green	6a	13a	Tan/Yellow	24	[AIN+]
[COMM_B]	12	Green/White	6b	13b	Yellow/Tan	25	[AIN-]
GPI [OUT1+]	13	White/Blue	7a	7b	Blue/White	26	GPI [OUT1-]

FEEDBACK CABLE (AEP-FC-10)

Cable assembly: CCC p/n 59-00786-000
Molded connector mates with drive J3 and has flying-lead terminations.

CONNECTOR (FRONT VIEW)

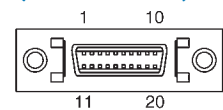

Signal	Pin	Color (Body/Stripe)	Pair		Color (Body/Stripe)	Pin	Signal
Frame Ground	1	Rev A & B: White/Tan Rev C: Brown	1a	8a	Rev A & B: Tan/White Rev C: Orange	11	Digital Hall U
Signal Ground	2	White/Brown	1b	8b	White/Blue	12	Digital Hall V
+5 Vdc @ 400 mA	3	Brown/White	2a	9a	Blue/White	13	Digital Hall W
Encoder Input A	4	White/Pink	2b	9b	White/Violet	14	[IN8] Motemp
Encoder Input /A	5	Pink/White	3a	10a	Violet/White	15	Signal Ground
Encoder Input B	6	White/Orange	3b	10b	White/Gray	16	Analog Sin(+)
Encoder Input /B	7	Orange/White	4a	11a	Gray/White	17	Analog Sin(-)
Encoder Input X	8	White/Yellow	4b	11b	Tan/Brown	18	Analog Cos(+)
Encoder Input /X	9	Yellow/White	5a	12a	Brown/Tan	19	Analog Cos(-)
Encoder S	10	White/Green	5b	12b	Green/White	20	Encoder /S

Note: Cable shields connect to connector shells and not to conductors. The shells of drive J3 & J4 are connected to the earth ground terminal on power connector J1 and to the drive chassis. When the cables above are connected to the drive a continuous path from cable shield to earth is established for shielding and CE compliance.

POWER DISSIPATION

The charts on this page show the drive internal power dissipation for the *Accelnet* models under differing power supply and output current conditions. Drive output current is calculated from the motion profile, motor, and load conditions. The values on the chart represent the RMS (root-mean-square) current that the drive would provide during operation. The +HV values are for the average DC voltage of the drive power supply.

When +HV and drive output current are known, the drive power dissipation can be found from the chart. Once this is done use the data on the facing page to find drive thermal resistance. From this calculate the maximum ambient operating temperature. If this result is lower than the known maximum ambient temperature then a mounting with a lower thermal resistance must be used.

When the drive is disabled the power dissipation is shown on the chart as "Off". Note that this is a different value than that of an drive that is "On" but outputting 0 A current.

55 & 90 VDC MODELS

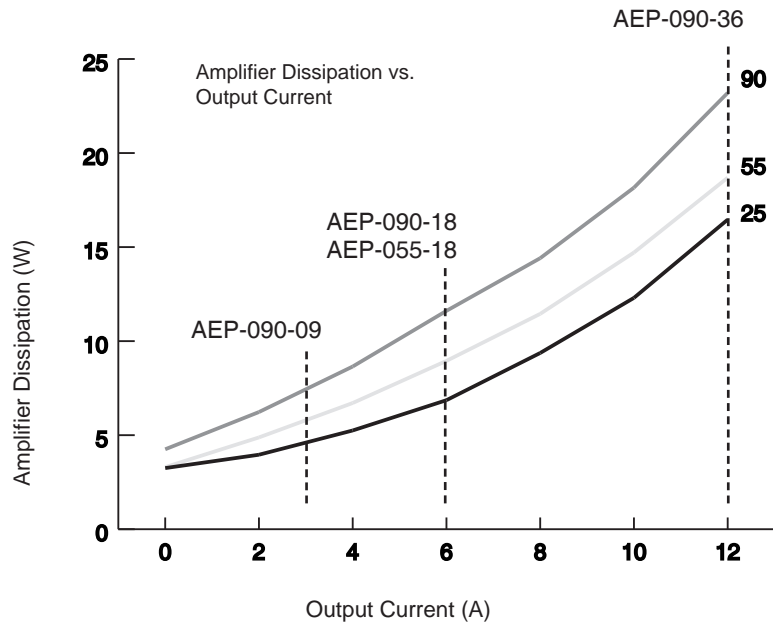

180 VDC MODELS

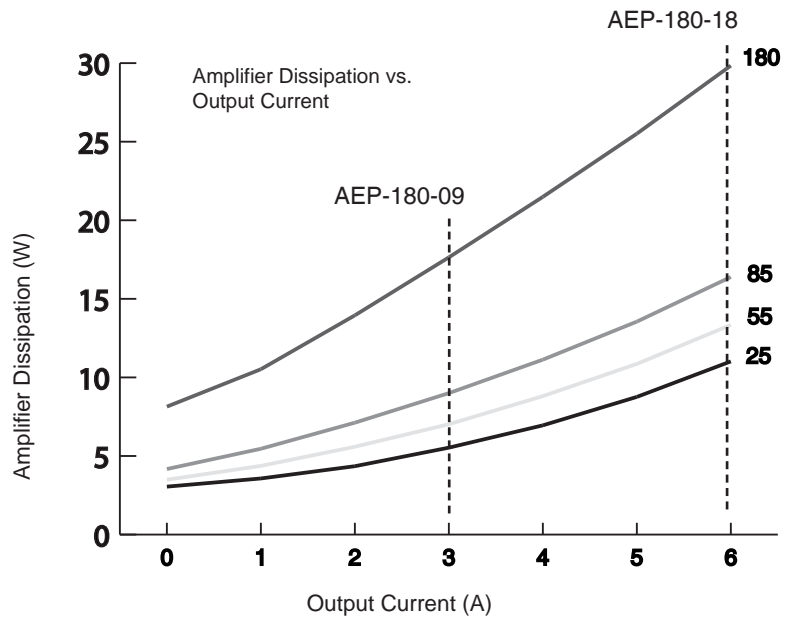

MOUNTING

Thermal data for convection-cooling with a heatsink assumes a vertical mounting of the drive on a thermally conducting surface. Heatsink fins run parallel to the long axis of the drive. When fan-cooling is used vertical mounting is not necessary to guarantee thermal performance of the heatsink.

THERMAL RESISTANCE

Thermal resistance is a measure of the temperature rise of the drive heatplate due to power dissipation in the drive. It is expressed in units of °C/W where the degrees are the temperature rise *above ambient*.

E.g., an drive dissipating 16 W mounted with no heatsink or fan would see a temperature rise of 46 °C above ambient based on the thermal resistance of 2.9 °C/W. Using the drive maximum heatplate temperature of 70 °C and subtracting 46 °C from that would give 24 °C as the maximum ambient temperature the drive in which the drive could operate before going into thermal shutdown. To operate at higher ambient temperatures a heatsink or forced-air would be required.

END VIEWS VERTICAL MOUNTING

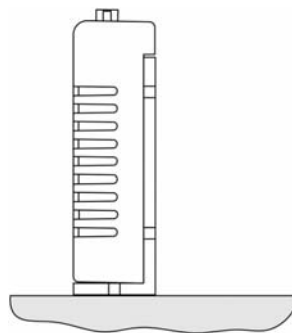

NO HEATSINK, NO FAN	°C/W
CONVECTION	2.9

TOP VIEW VERTICAL MOUNTING WITH FAN

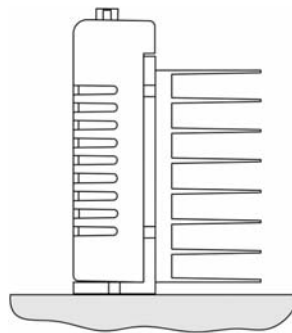
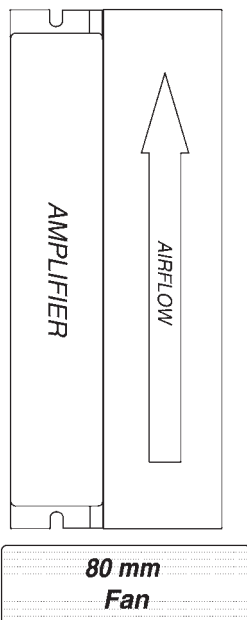

HEATSINK, NO FAN	°C/W
CONVECTION	1.7

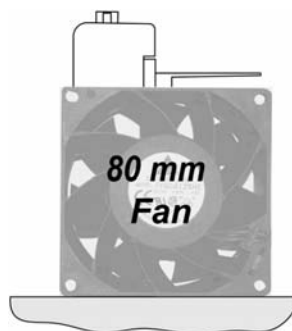

HEATSINK + FAN	°C/W
FORCED-AIR, 300 LFM	0.6

DIMENSIONS

Units: Inches (mm).

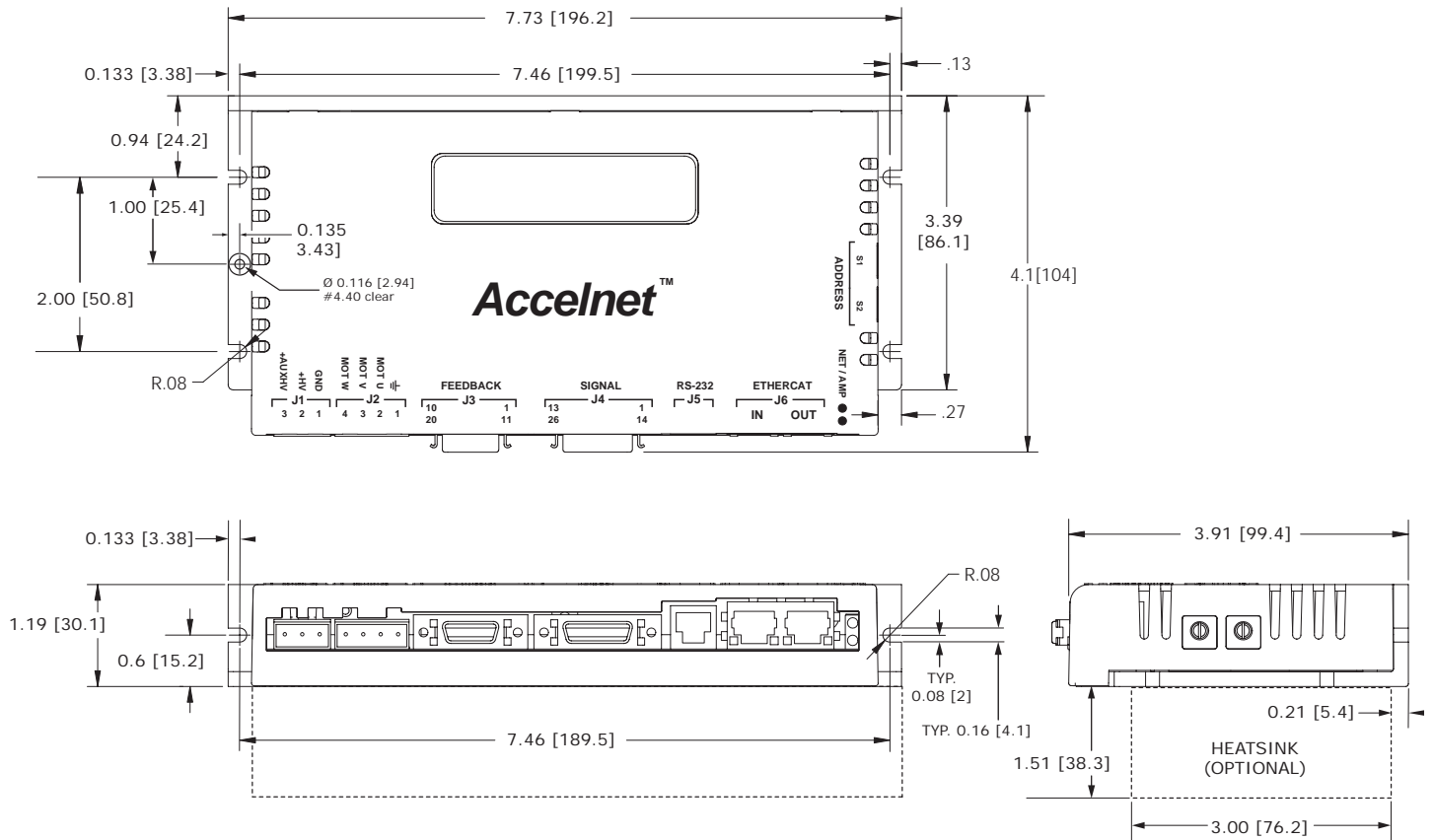

MASTER ORDERING GUIDE

AEP-055-18	Accelnet EtherCAT® servo drive, 6/18 A, 55 Vdc
AEP-090-09	Accelnet EtherCAT® servo drive, 3/9 A, 90 Vdc
AEP-090-18	Accelnet EtherCAT® servo drive, 6/18 A, 90 Vdc
AEP-090-36	Accelnet EtherCAT® servo drive, 12/36 A, 90 Vdc
AEP-180-09	Accelnet EtherCAT® servo drive, 3/9 A, 180 Vdc
AEP-180-18	Accelnet EtherCAT® servo drive, 6/18 A, 180 Vdc



ACCESSORIES

	QTY	REF	DESCRIPTION	MANUFACTURER PART NO.
Connector Kit Solder-Cup AEP-CK	1	J1	Plug, 3 position, 5.08 mm, female	PCD: ELFP03210, Weco: 121-A-111/03
	1	J2	Plug, 4 position, 5.08 mm, female	PCD: ELFP04210, Weco: 121-A-111/04
	1	J3	20 Pin Connector, High Density, D-Sub, Solder Cup	3M: 10120-3000VE
	1		20 Pin Connector Backshell	3M: 10320-52F0-008
	1	J4	26 Pin Connector, High Density, D-Sub, Solder Cup	3M: 10126-3000VE
	1		26 Pin Connector Backshell	3M: 10326-52F0-008
Connector Kit Cable Assy AEP-CA	1	J1	Plug, 3 position, 5.08 mm, female	PCD: ELFP03210, Weco: 121-A-111/03
	1	J2	Plug, 4 position, 5.08 mm, female	PCD: ELFP04210, Weco: 121-A-111/04
	1	J3	Cable assembly, control, 10 ft (3 m)	Molex: 52316-2611, plug assy, Molex 52370-2610 boot cover
	1	J4	Cable assembly, feedback, 10 ft (3 m)	Molex: 52316-2011, plug assy, Molex 52370-2010 boot cover
AEP-CC-10		J3	Cable assembly, control, 10 ft (3 m)	Molex: 52316-2611, plug assy, Molex 52370-2610 boot cover
AEP-FC-10		J4	Cable assembly, feedback, 10 ft (3 m)	Molex: 52316-2011, plug assy, Molex 52370-2010 boot cover
AEP-NC-10		J6	EtherCAT® network cable, 10 ft (3 m)	
AEP-NC-01		J6	EtherCAT® network cable, 1 ft (0.3 m)	
SER-CK		J5	Serial Cable Kit: D-Sub 9 female to drive J5 connector, 6 ft (1.8 m)	
CME 2			CME 2™ CD (CME 2)	
Heatsink Kit AEP-HK	1		Heatsink	
	1		Thermal Material	
		AR	Hardware	

Note: To order drive with heatsink installed at factory, add "-H" to the drive part number. E.g., AEP-090-18-H

ORDERING INSTRUCTIONS

Example: Order 1 AEP-090-18 drive with heatsink installed at factory and associated components:

Qty	Item	Remarks
1	AEP-090-18-H	Accelnet EtherCAT® servo drive
1	AEP-CK	Connector Kit
1	SER-CK	Serial Cable Kit
1	CME2	CME 2™ CD

EtherCAT® is a registered trademark and patented technology, licensed by Beckhoff Automation GmbH, Germany.

Note: Specifications subject to change without notice

Rev 10.04_tu 02/23/2010