

Parker

Manual No. 102-5871-01

Rev. E

401/402/403XE Series Product Manual

Effective: June 10, 2021

Supersedes: October 3, 2018

Electromechanical Positioning Systems



Important User Information

WARNING

FAILURE OR IMPROPER SELECTION OR IMPROPER USE OF THE PRODUCTS AND/OR SYSTEMS DESCRIBED HEREIN OR RELATED ITEMS CAN CAUSE DEATH, PERSONAL INJURY AND PROPERTY DAMAGE.

This document and other information from Parker Hannifin Corporation, its subsidiaries, and authorized distributors provide product and/or systems options for further investigation by users having technical expertise. It is important that you analyze all aspects of your application and review the information concerning the product or system in the current product catalog. Due to the variety of operating conditions and applications for these product systems, the user, through its own analysis and testing, is solely responsible for making the final selection of the products and systems and assuming that all performance, safety, and warning requirements of the application are met.

The products described herein, including without limitation, product features, specifications, designs, availability and pricing, are subject to change by Parker Hannifin Corporation and its subsidiaries at any time without notice.

The information in the product manual, including any apparatus, methods, techniques, and concepts described herein, are the proprietary property of Parker Hannifin Corporation, Electromechanical Automation-Parker or its licensors, and may not be copied, disclosed, or used for any purpose not expressly authorized by the owner thereof.

Since Parker Hannifin Corporation, Electromechanical Automation-Parker constantly strives to improve all of its products, we reserve the right to change this product manual and equipment mentioned therein at any time without notice.

.....
• *For assistance contact:*
• Parker Hannifin Corporation
• Electromechanical Automation-Daedal
• 1140 Sandy Hill Road
• Irwin, PA 15642
• Phone: 724/861-8200
• 800/245-6903
• Fax: 724/861-3330
• E-mail: ddlcat@parker.com
• Web site: www.parkermotion.com
.....

401/402/403XE Series Product Manual

Table of Contents

IMPORTANT USER INFORMATION	2
REVISION NOTES	4
CHAPTER 1 - INTRODUCTION	5
PRODUCT DESCRIPTION	5
UNPACKING.....	5
RETURN INFORMATION	6
REPAIR INFORMATION	6
WARNINGS AND PRECAUTIONS	6
SPECIFICATION CONDITIONS	7
ASSEMBLY DIAGRAMS	8
CHAPTER 2 - 401/402/403XE SPECIFICATIONS	9
ORDER NUMBER NOMENCLATURE - 401XE, 402XE, 403XE	9
DIMENSIONAL DRAWINGS - 401XE	10
DIMENSIONAL DRAWINGS - 402XE	12
DIMENSIONAL DRAWINGS - 403XE	14
PERFORMANCE SPECIFICATIONS - 401XE	16
PERFORMANCE SPECIFICATIONS - 402XE	17
PERFORMANCE SPECIFICATIONS - 403XE	18
TEST METHODOLOGY	19
TECHNICAL DATA - 401/402/403XE	20
CLEAN ROOM PREPARATION	22
CHAPTER 3 - COMPONENT SPECIFICATIONS	23
MOTOR INFORMATION	23
LIMIT/HOME SWITCH INFORMATION - 402/403XE	23
COUPLING INFORMATION.....	24
CHAPTER 4 - SETUP AND USAGE	25
MOUNTING ORIENTATION	25
MOUNTING SURFACE REQUIREMENTS	25
BASE THROUGH HOLE MOUNTING - 402/403XE	25
RISER PLATES.....	26
PAYLOAD MOUNTING.....	26
INLINE MOTOR MOUNTING.....	27
PARALLEL MOTOR MOUNTING - 404XE	27
LIMIT/HOME SWITCH ADJUSTMENT - 402/403XE	29
LIMIT/HOME SWITCH ADJUSTMENT - 404XE.....	29
CHAPTER 5 - MAINTENANCE AND REPAIR	30
LINEAR BEARING & BALLSCREW LUBRICATION - 401/402/403XE	30
APPENDIX A - ACCESSORIES & SPARE PARTS	31
APPENDIX B - INTERNAL PROTECTION	34
APPENDIX C - COMPLIANCE	35

Revision Notes

Revision (-) 4/2014 Original Document
(New document created from 102-0988-01 , now 404XE only)

Revision A 3/9/17
Page 24, Clamp screw torque listed as 9 changed to 7

Revision B 8/28/17
Page 9 - change MPE 040 to PM-FAL servo motor mount
Page 12-17 remove all MPE040 references

Revision C 5/18/18
Page 23- change picture, remove reference for part numbers

Revision D 10/3/18
Page 6, Add warnings for CE certification

Revision E 6/10/21
Updated lubrication information.

Chapter 1 - Introduction

Product Description

401XE Positioner

The 401XE is a linear positioning table, targeted for a blend of performance and value, of just under 1.2" width which provides travel length up to 160mm. The recirculating linear bearings support up to 16kg normal load. It features a ballscrew drive of 2mm lead, and is available with several motor mount and limit/home switch options.

402XE Positioner

The 402XE is a linear positioning table, targeted for a blend of performance and value, of approximately 2" width which provides travel length up to 220mm. The recirculating linear bearings support up to 90kg normal load. It features a ballscrew drive of either 2mm or 5mm lead, and is available with several motor mount and limit/home switch options.

403XE Positioner

Similar to but larger than the 402XE, the 403XE is a linear positioning table of just under 3" width which provides travel length up to 655mm. The recirculating linear bearings support up to 160kg normal load. It also features a ballscrew drive of either 5mm or 10mm lead, and is available with several motor mount and limit/home switch options.

Unpacking



Unpacking

Carefully remove the positioner from the shipping container and inspect the unit for any evidence of shipping damage. Report any damage immediately to your local authorized distributor. Please save the shipping container for damage inspection or future transportation.

Incorrect handling of the positioner may adversely affect the performance of the unit in its application. Please observe the following guidelines for handling and mounting of your new positioner.

- DO NOT allow the positioner to drop onto the mounting surface. Dropping the positioner can generate impact loads that may result in flat spots on bearing surfaces or misalignment of drive components.
- DO NOT drill holes into the positioner. Drilling holes into the positioner can generate particles and machining forces that may effect the operation of the positioner. Parker will drill holes if necessary; contact your local authorized distributor.
- DO NOT subject the unit to impact loads such as hammering, riveting, etc. Impacts loads generated by hammering or riveting may result in flat spots on bearing surfaces or misalignment of drive components.
- DO NOT lift the positioner by the cables. Lifting positioner by the cables may effect electrical connections. The unit should be lifted by the base structure only.
- DO NOT expose positioner to mist, spray or submersion in liquids.
- DO NOT disassemble positioner. Unauthorized adjustments may alter the positioner's specifications and void the product warranty.

Return Information

Returns

All returns must reference a "Return Material Authorization" (RMA) number. Please call your local authorized distributor or Parker Customer Service Department at 800-245-6903 to obtain an "RMA" number.

Repair Information

Out-of-Warranty Repair

Our Customer Service Department repairs Out-of-Warranty products. All returns must reference an "RMA" number. Please call your local authorized distributor or Parker Customer Service Department at 800-245-6903 to obtain an "RMA" number. You will be notified of any cost prior to making the repair.

Warnings and Precautions



Hot Surfaces

DO NOT touch rotary motor coils located on the positioner after high duty operation. Motor temperature may approach 60°C.



Electrical Shock

DO NOT take apart or touch any internal components of the positioner while unit is plugged into an electrical outlet. SHUT OFF power before replacing components to avoid electrical shock.



Vertical Operation

Depending on your load and drive screw selection the carriage and load may backdrive in power loss situations potentially causing product damage or personal injury.



Strain Relieve Electrical Components

All electrical components (such as motors and limit/home switches) must be strain relieved. Failure to strain relieve electrical wires or cables may result in component failure and/or personal injury.



General Safety

Sometimes positioning equipment moves without warning. Keep all personnel away from dynamic travel range.



Pinch points

Product does have pinch areas where moving elements relative to each other come together- Take precaution.

Specification Conditions

Specifications Are Temperature Dependent

Catalog specifications are obtained and measured at 20°C. Specifications at any other temperature may deviate from catalog specifications. Minimum to maximum continuous operating temperature range (with NO guarantee of any specification except motion) of a standard unit before failure is 5°C to 40°C.

Specifications Are Mounting Surface Dependent

Catalog specifications are obtained and measured when the positioner is fully supported, bolted down, and is mounted to a work surface that has a maximum flatness error of 0.013mm/300mm (0.0005"/ft)

Specifications Are Point of Measurement Dependent

Catalog specifications and specifications in this manual are measured from the center of the carriage, 37.5mm above the carriage surface. All measurements taken at any other location may deviate from these values.

Assembly Diagrams

401/402/403XE

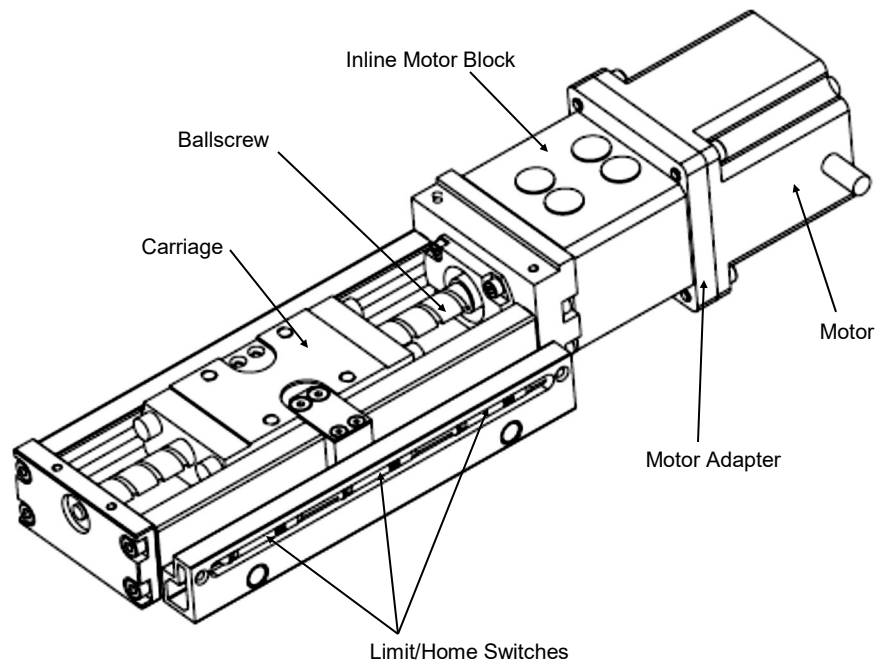
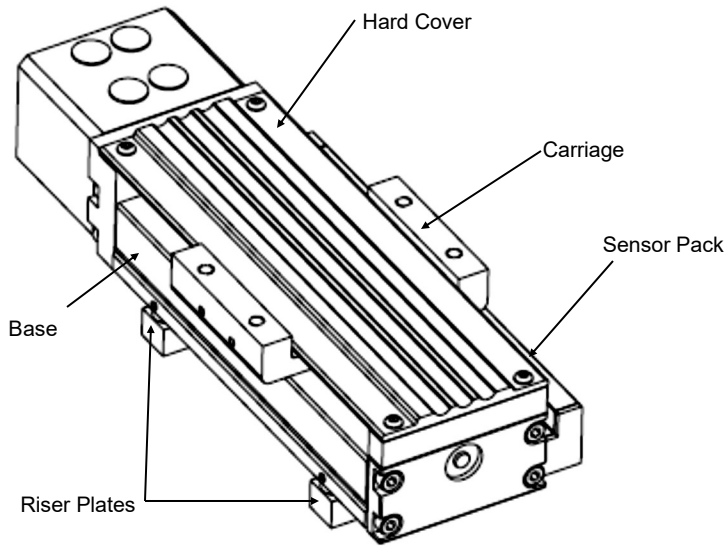

Chapter 2 - 401/402/403XE Specifications

Order Number Nomenclature

- ① ② ③ ④ ⑤ ⑥ ⑦ ⑧ ⑨ ⑩ ⑪ ⑫ ⑬

Order Example:



- ① **Series**
401
402
403

② **Travel**

01	60 mm	70 mm	55 mm
02	110 mm	120 mm	105 mm
03	160 mm	170 mm	205 mm
04	-	220 mm	305 mm
05	-	-	405 mm
06	-	-	505 mm
07	-	-	605 mm
08	-	-	655 mm

- ③ **Family**
XE XE Series

- ④ **Grade**
S Standard

- ⑤ **Drive Screw**
D9 2mm lead
D2 5 mm lead
D3 10 mm lead

- ⑥ **Home Sensor (Qty 1)**
H0 No Home sensor
HA NPN, N.C., flying leads
HB NPN, N.O., flying leads
HC PNP, N.C., flying leads
HD PNP, N.O., flying leads

- ⑦ **Limit Sensors (Qty 2)**
L0 No Limit sensor
LA NPN, N.C., flying leads
LB NPN, N.O., flying leads
LC PNP, N.C., flying leads
LD PNP, N.O., flying leads

- ⑧ **Motor Mount Orientation**
L Inline motor mounting
A Parallel motor mounting, 3:00
B Parallel motor mounting, 6:00
C Parallel motor mounting, 9:00

- ⑨ **Motor Options**
N00 No motor mount
N11 NEMA 11 motor mount
N17 NEMA 17 motor mount
N16 SM16 servo motor mount
N40 PM-FAL servo motor mount
N23 NEMA 23 motor mount
M11 NEMA 11 stepper motor
M17 NEMA 17 stepper motor
M16 SM162AE-NLCN servo motor
M23 NEMA 23 stepper motor

- ⑩ **Motor Coupling**
C1 No coupler
C2 0.25" Oldham
C3 0.25" Bellows
C4 0.375" Oldham
C5 0.375" Bellows
C6 5 mm Oldham
C7 5 mm Bellows
C8 8 mm Oldham
C9 8 mm Bellows

- ⑪ **Motor Encoder**
E0 No encoder
E2 500 line encoder

- ⑫ **Environmental Option**
R0 No cover
R1 Hard cover

- ⑬ **Orthogonality Axis Options**
P0 Single axis

Dimensional Drawings - 401XE

401XE with Hard Cover

401XE without Hard Cover

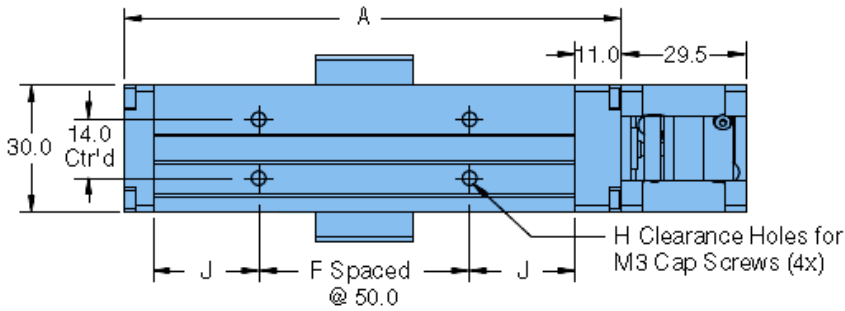
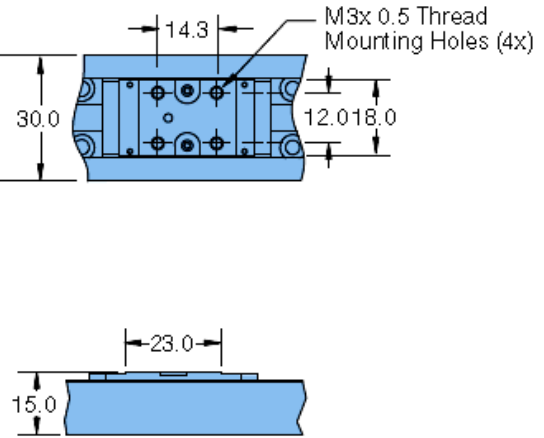
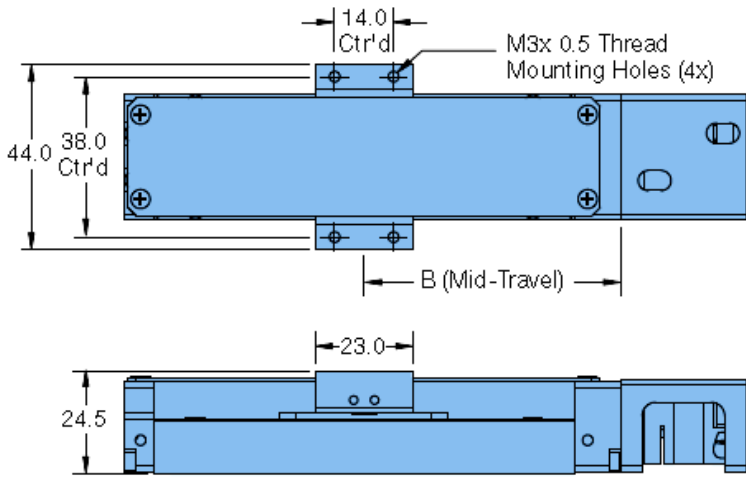

Optional Limit/Home Sensor

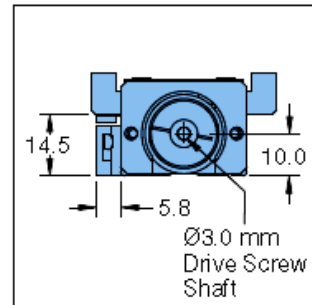

Travel Option	Travel	"A"	"B"	"F"	"G"	"H"	"J"
01	60 mm	118	61	1	50	4	25
02	110 mm	168	86	2	100	6	25
03	160 mm	218	111	3	150	8	25

Visit
www.parkermotion.com
 for 2D CAD and 3D Models

401XE with Inline Motor - NEMA 11 & 17

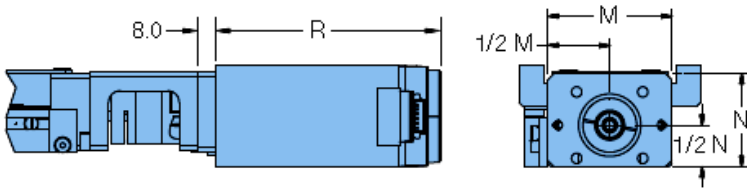

Motor Option	Motor or Motor Size	"L"	"M"	"N"	"R"
M11	NEMA 11	7.0	30.0	28.0	62.2
M17	NEMA 17	7.0	42.0	42.0	58.2

401XE with NEMA 11 Parallel Motor

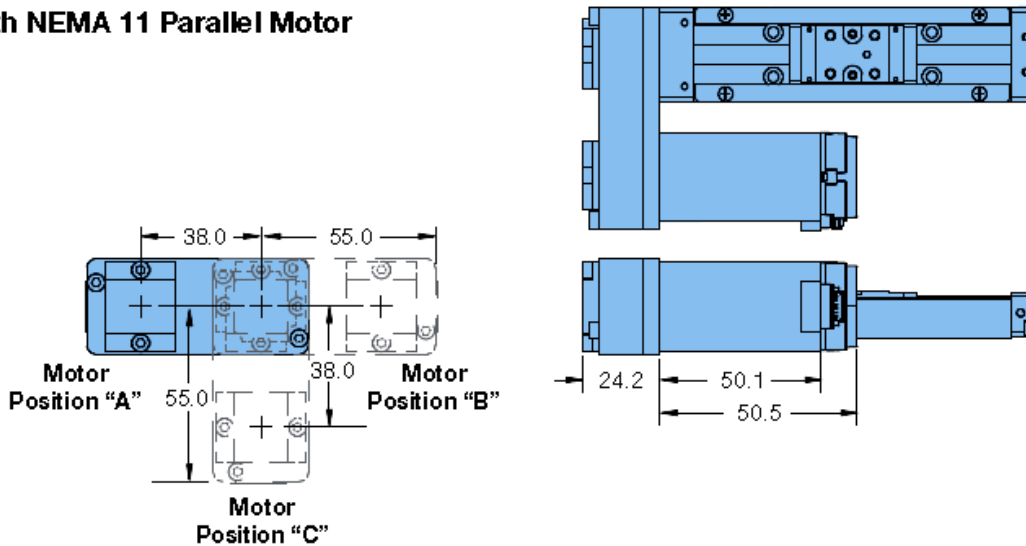

401XE with NEMA 17 Parallel Motor

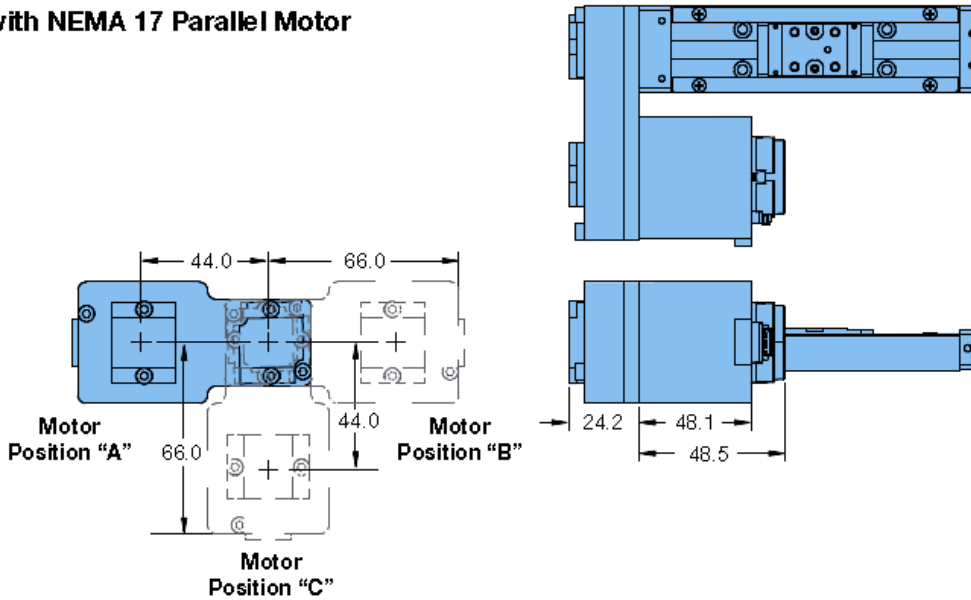

Dimensional Drawings - 402XE

402XE with Hard Cover

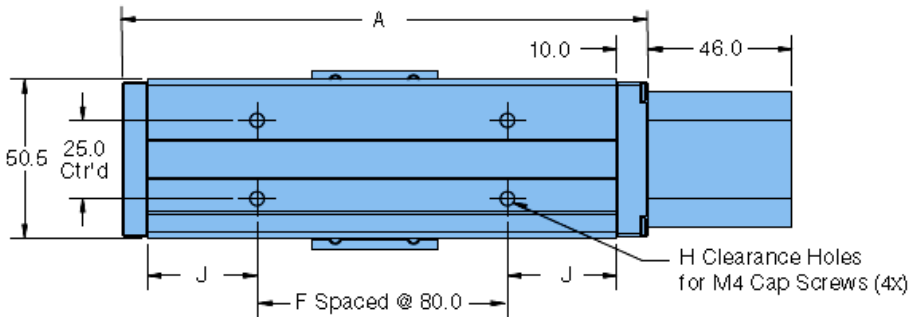
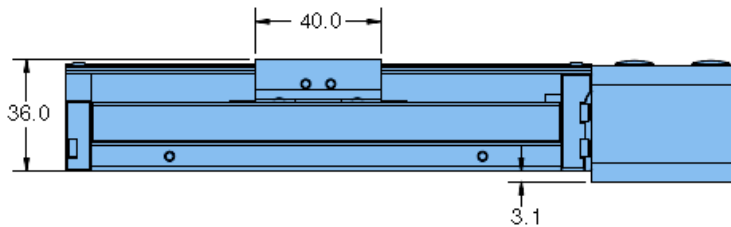
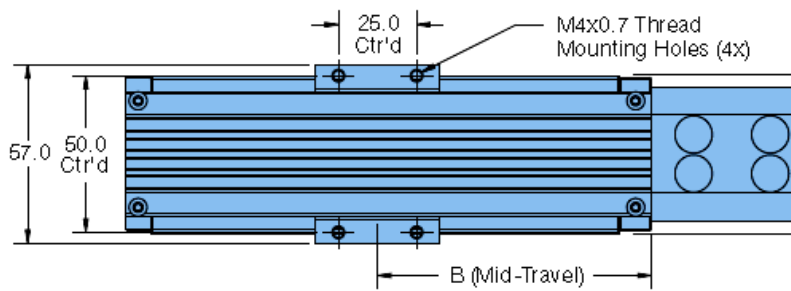

402XE without Hard Cover

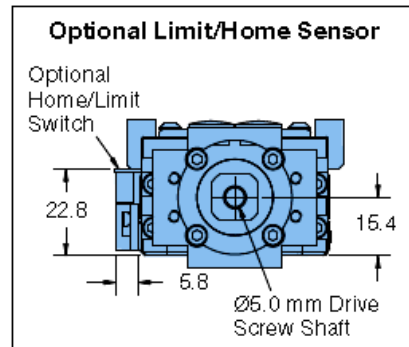
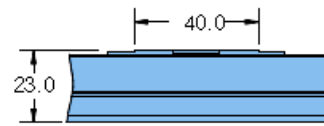
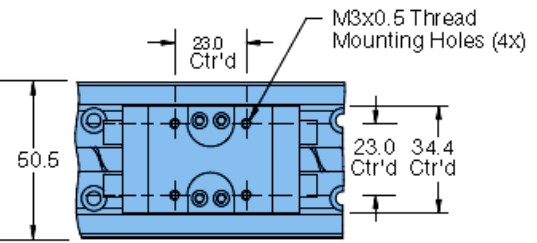

Travel Option	Travel	"A"	"B"	"F"	"G"	"H"	"J"
01	70 mm	168.0	87.5	1	80.0	4	35.0
02	120 mm	218.0	112.5	2	160.0	6	20.0
03	170 mm	268.0	137.5	2	160.0	6	45.0
04	220 mm	318.0	162.5	3	240.0	8	30.0

Visit
www.parkermotion.com
for 2D CAD and 3D Models

402XE with Inline Motor

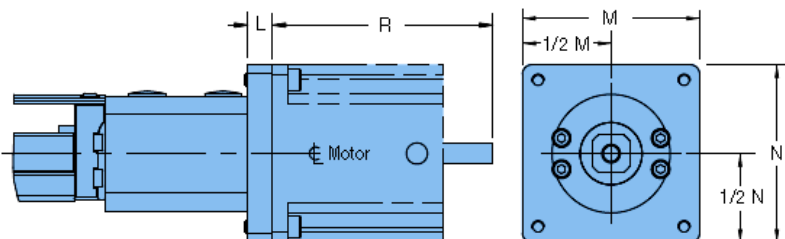

Motor Option	Motor or Motor Size	"L"	"M"	"N"	"R"
M17	NEMA17	8.0	40.6	40.6	58.2
M16	SM162AE-N10N	8.0	57.2	57.2	124.0
M23	NEMA 23	8.0	57.2	57.2	72.4

402XE with NEMA 17 Parallel Motor

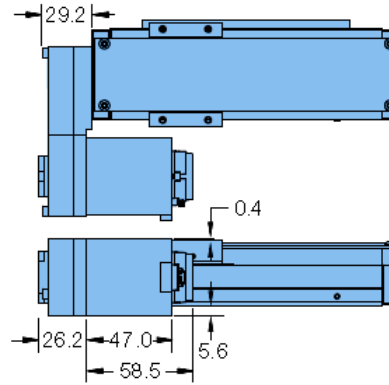
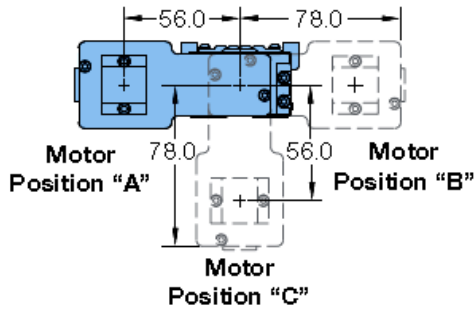

402XE with SM16 Parallel Motor

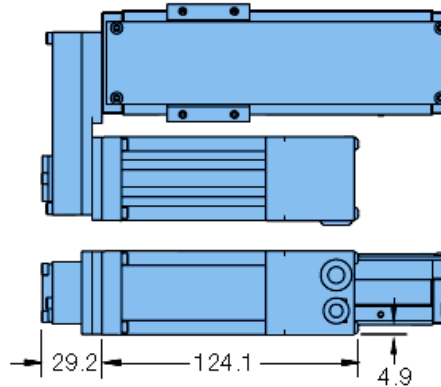
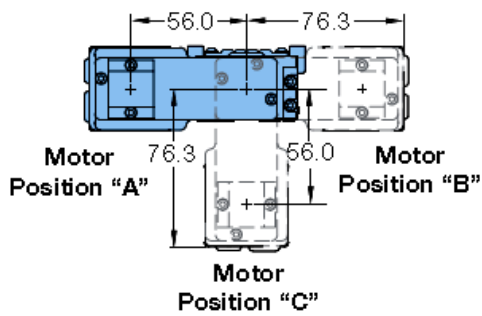

Dimensional Drawings - 403XE

403XE with Hard Cover

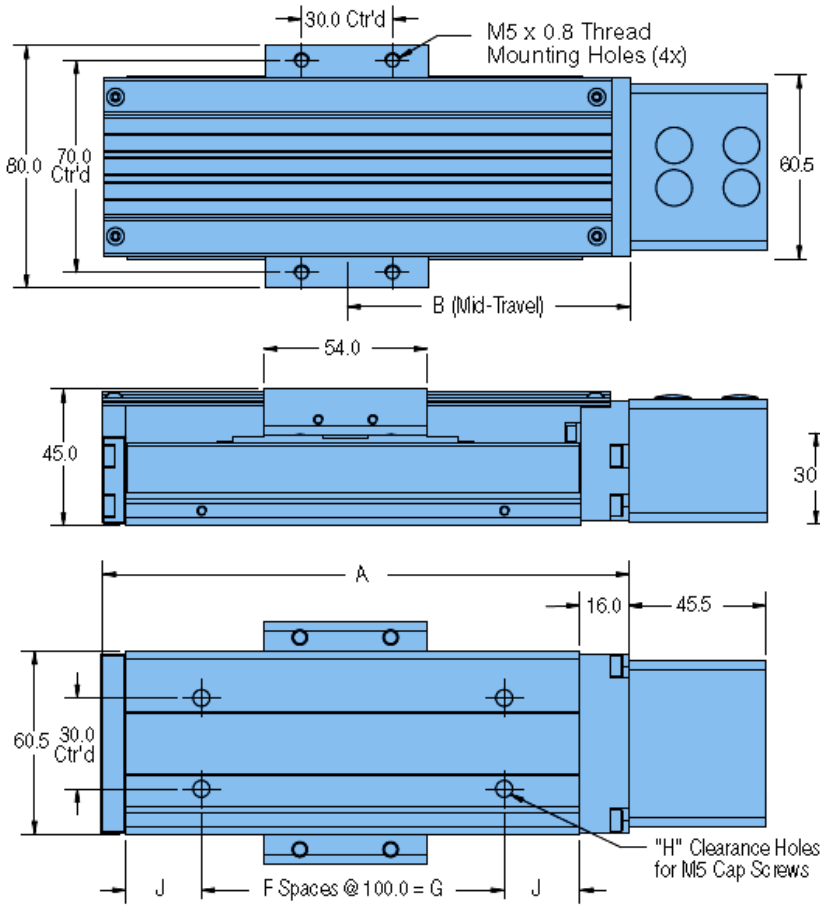

403XE without Hard Cover

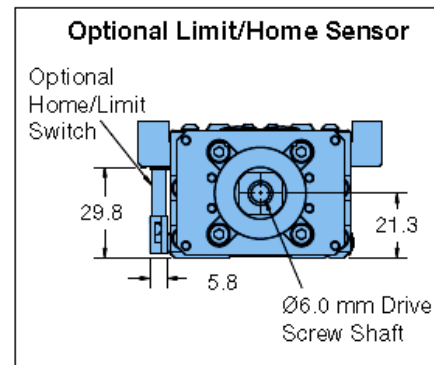
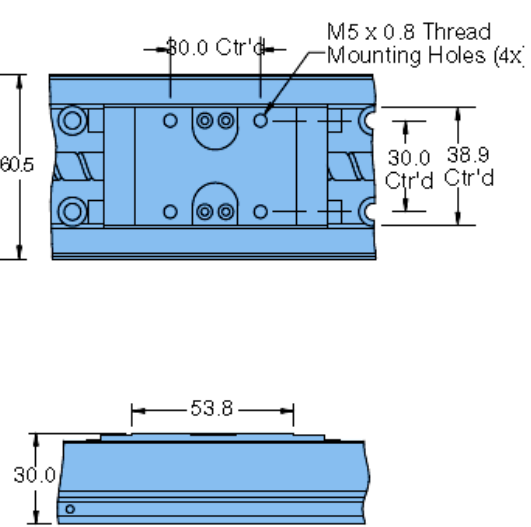

Travel Option	Travel	"A"	"B"	"F"	"G"	"H"	"J"
01	55 mm	174.0	93.5	1	100.0	4	25.0
02	105 mm	224.0	118.5	1	100.0	4	50.0
03	205 mm	324.0	168.5	2	200.0	6	50.0
04	305 mm	424.0	218.5	3	300.0	8	50.0
05	405 mm	524.0	268.5	4	400.0	10	50.0
06	505 mm	624.0	318.5	5	500.0	12	50.0
07	605 mm	724.0	368.5	6	600.0	14	50.0
08	655 mm	774.0	393.5	7	700.0	16	25.0

Visit
www.parkermotion.com
 for 2D CAD and 3D Models

403XE with Inline Motor

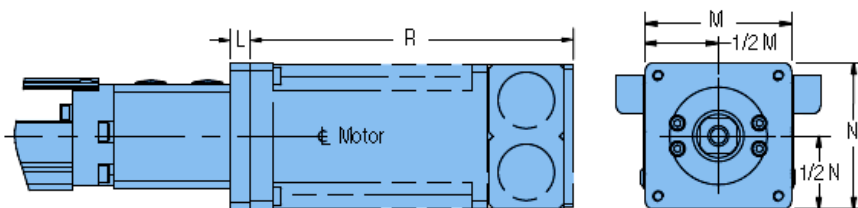

Motor Option	Motor or Motor Size	"L"	"M"	"N"	"R"
M17	NEMA17	8.0	40.6	40.6	58.2
M16	SM162AE-N10N	8.0	57.2	57.2	124.0
M23	NEMA 23	8.0	57.2	57.2	72.4

403XE with NEMA 17 Parallel Motor

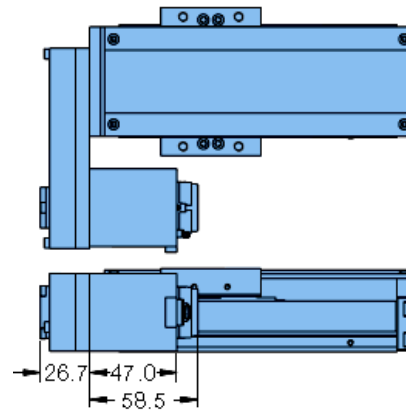
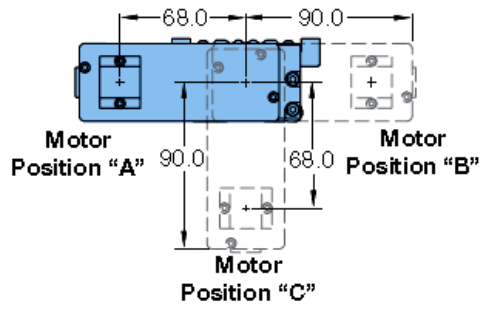

403XE with SM16 Parallel Motor

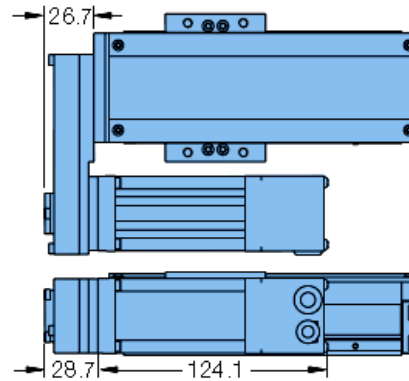
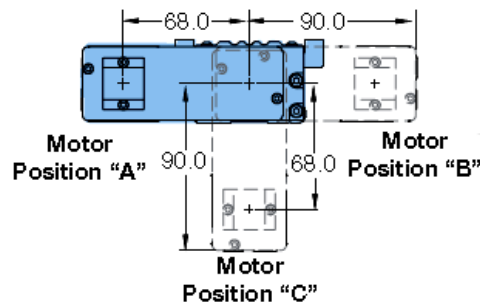

403XE with NEMA 23 Parallel Motor

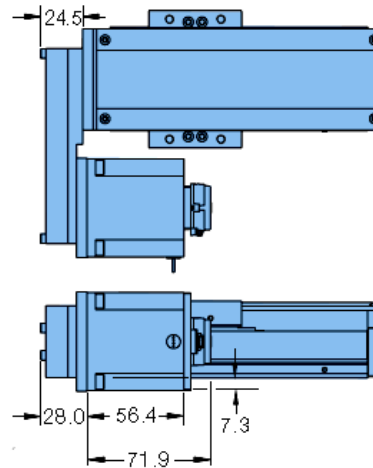
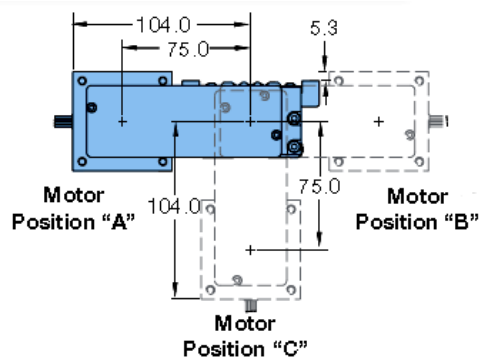

Performance Specifications - 401XE

401XE Common Performance Characteristics

	Unit	2mm Lead (D9 Option)
Bidirectional Repeatability - μm Inline Motor Mount Parallel Motor Mount	μm	± 10
		± 30
Breakaway Torque	Nm	0.012
Maximum Input Speed	rev/sec	50
Maximum Velocity	mm/sec	100
Maximum Load (Normal and Inverted)	kg	16
Maximum moment Roll Yaw Pitch	Nm	10
		11
		28
Screw Diameter	mm	6
Screw Efficiency Inline Motor Mount Parallel Motor Mount	%	90
		86
Linear Bearing Coefficient of Friction	-	0.01
Running Torque	Nm	0.011
Maximum Axial Load	kg	5
Moment of Inertia I_x of Guide Rail I_y of Guide Rail	mm^4	2710
		23,600
Weight of Carriage	kg	0.05
Maximum Acceleration	G's	2
Rated Duty Cycle	%	100

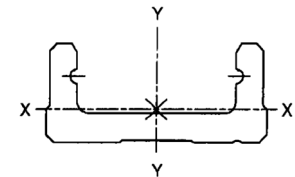

401XE Travel Dependent Performance Characteristics - 2 mm Lead

Travel Option	Travel - mm	Flatness - μm	Straightness - μm	Accuracy μm		Input Inertia - $\text{kg}\cdot\text{m}^2 \times 10^{-4}$		Weight - Inline mount - kg
				Inline	Parallel	Inline	Parallel	
01	60	15	15	65	95	0.122	0.327	0.41
02	110	15	15	70	100	0.171	0.376	0.49
03	160	15	15	75	105	0.224	0.429	0.58

* Adding the parallel motor mount option adds 0.08 kg for the NEMA 11 options and 0.10 kg for the NEMA 17 option.

Performance Specifications - 402XE

402XE Common Performance Characteristics

	Unit	2mm Lead	5mm Lead
Bidirectional Repeatability - μm Inline Motor Mount Parallel Motor Mount	μm	± 5	± 5
		± 15	± 30
Breakaway Torque	Nm	0.006	0.06
Maximum Input Speed	rev/sec	50	50
Maximum Velocity	mm/sec	100	250
Maximum Load (Normal and Inverted)	kg	90	90
Maximum moment Roll Yaw Pitch	Nm	46	46
		51	51
		134	134
Screw Diameter	mm	8	8
Screw Efficiency Inline Motor Mount Parallel Motor Mount	%	90	90
		86	86
Linear Bearing Coefficient of Friction	-	0.01	0.01
Running Torque	Nm	0.05	0.05
Maximum Axial Load	kg	13	17
Moment of Inertia I_x of Guide Rail I_y of Guide Rail	mm^4	14,400	14,400
		137,000	137,000
Weight of Carriage	kg	0.26	0.26
Maximum Acceleration	G's	2	2
Rated Duty Cycle	%	100	100

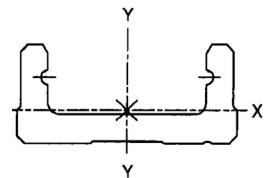

402XE Travel Dependent Performance Characteristics - 2 mm Lead

	Travel Option	Travel - mm	Flatness - μm	Straightness - μm	Accuracy μm		Input Inertia - $\text{kg}\cdot\text{m}^2 \times 10^{-6}$		Weight - Inline mount - kg
					Inline	Parallel	Inline	Parallel	
2 mm Lead	01	70	15	15	70	85	0.615	0.82	1.19
	02	120	15	15	75	90	0.772	0.977	1.40
	03	170	15	15	85	100	0.929	1.134	1.60
	04	220	15	15	90	105	1.090	1.295	1.81
5 mm Lead	01	70	15	15	70	85	0.741	0.946	1.19
	02	120	15	15	75	90	0.898	1.103	1.40
	03	170	15	15	85	100	1.060	1.265	1.60
	04	220	15	15	90	105	1.210	1.415	1.81

* Adding the parallel motor mount option adds 0.11 kg for the NEMA 17 options, 0.15 kg for the NEMA 23 option, and 0.12 kg for the SM16 option.

Performance Specifications - 403XE

403XE Common Performance Characteristics

	Unit	5mm Lead	10 mm Lead
Bidirectional Repeatability - μm			
Inline Motor Mount	μm	± 5	± 5
Parallel Motor Mount		± 30	± 60
Breakaway Torque	Nm	0.15	0.15
Maximum Input Speed	rev/sec	50	50
Maximum Velocity	mm/sec	150	500
Maximum Load (Normal and Inverted)	kg	160	160
Maximum moment			
Roll	Nm	101	101
Yaw		120	120
Pitch		260	260
Screw Diameter	mm	10	10
Screw Efficiency			
Inline Motor Mount	%	90	90
Parallel Motor Mount		86	86
Linear Bearing Coefficient of Friction	-	0.01	0.01
Running Torque	Nm	0.1	0.1
Maximum Axial Load	kg	31	27
Moment of Inertia			
I_x of Guide Rail	mm^4	38,800	38,800
I_y of Guide Rail		314,000	314,000
Weight of Carriage	kg	0.3	0.3
Maximum Acceleration	G's	2	2
Rated Duty Cycle	%	100	100

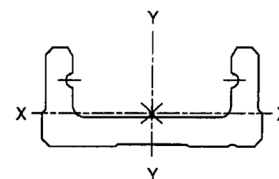

403XE Travel Dependent Performance Characteristics - 2 mm Lead

	Travel Option	Travel - mm	Flatness - μm	Straightness - μm	Accuracy μm		Input Inertia - $\text{kg}\cdot\text{m}^2 \times 10^{-6}$		Weight - Inline mount - kg
					Inline	Parallel	Inline	Parallel	
5 mm Lead	01	55	15	15	70	100	1.720	1.925	1.85
	02	105	15	15	80	110	2.100	2.305	2.25
	03	205	15	15	90	120	2.870	3.075	2.85
	04	305	15	15	95	125	3.630	3.835	3.55
	05	405	25	25	100	130	4.400	4.605	4.25
	06	505	25	25	110	140	5.170	5.375	4.85
	07	605	25	25	120	150	5.930	6.135	5.55
	08	655	-	-	-	0	-	0	-
10 mm Lead	01	55	15	15	70	130	2.500	2.705	1.85
	02	105	15	15	80	140	2.880	3.085	2.25
	03	205	15	15	90	150	3.650	3.855	2.85
	04	305	15	15	95	155	4.420	4.625	3.55
	05	405	25	25	100	160	5.180	5.385	4.25
	06	505	25	25	110	170	5.950	6.155	4.85
	07	605	25	25	120	180	6.700	6.905	5.55
	08	655	-	-	130	190	7.100	7.305	-

* Adding the parallel motor mount option adds 0.11 kg for the NEMA 17 option, 0.15 kg for the NEMA 23 option, and 0.12 kg for the SM16 option..

Test Methodology

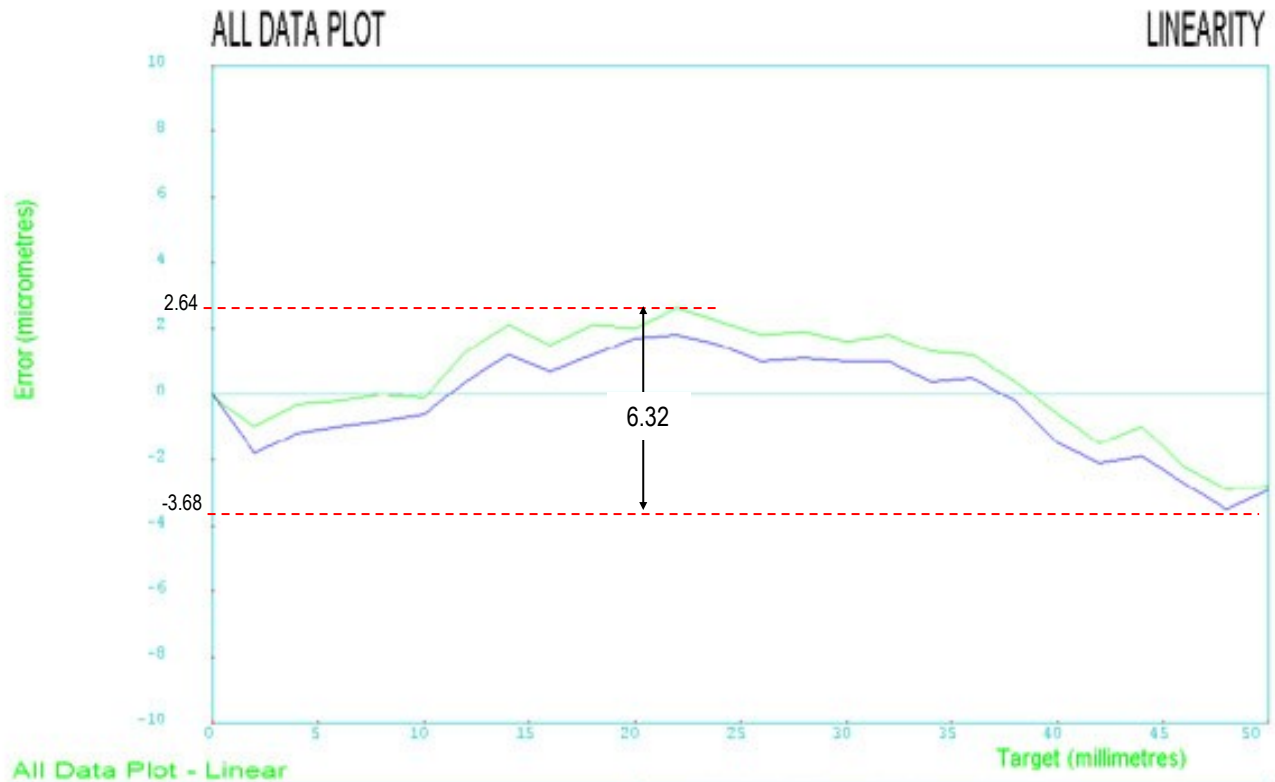

Published accuracy and repeatability specifications are subject to the testing methodology. Parker's methodology provides specifications over the entire table travel regardless of start or finish position. The accuracy and repeatability specifications are based on the peak to peak error measured by a laser interferometer and prism located at 37.5mm above the center of the table. This type of measurement sums the X, Y, Z, roll, pitch, and yaw errors. Temperature deviations from test condition may cause deviations in straightness, flatness, accuracy, and repeatability from catalog specifications. Tests are performed with the table mounted to a granite table, unloaded at 20° C.

In this example, the accuracy ranges from -3.68 microns to 2.64 microns. This table would have its accuracy specified as 6.32 micron since the worst case would be starting at one extreme and traveling to the other.

Technical Data - 401/402/403XE

The following performance information is provided as a supplement to the product specifications pages. The useful life of a linear table at full catalog specifications is dependent on the forces acting upon it. These forces include both static components resulting from payload weight, and dynamic components due to acceleration and deceleration of the load. In multi-axis applications, the primary positioner at the bottom of the stack usually establishes the load limits for the combined axes. When evaluating life versus load, it is critical to include the weight of all positioning elements that contribute to the load supported by the primary axis. The following graphs are used to establish the table life relative to the applied loads.

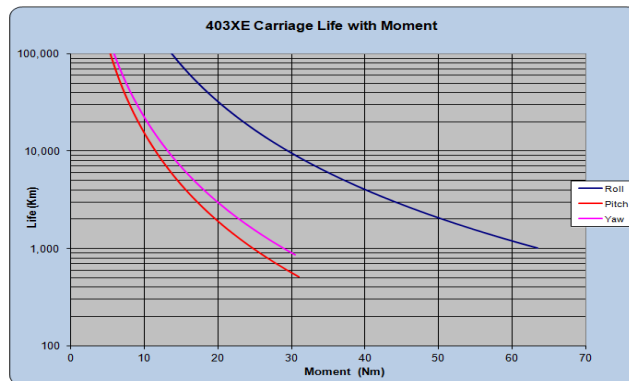
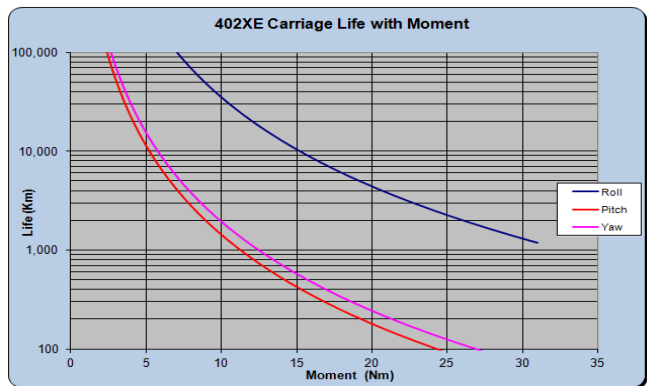
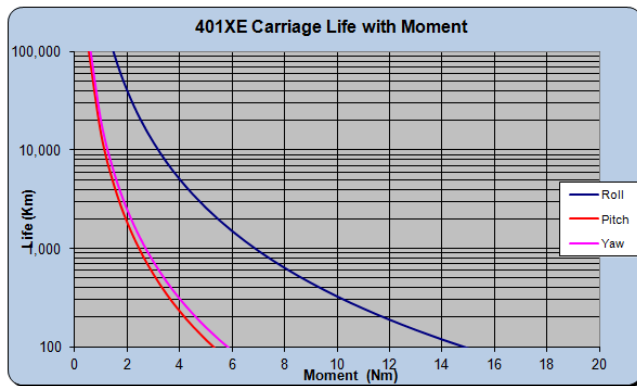
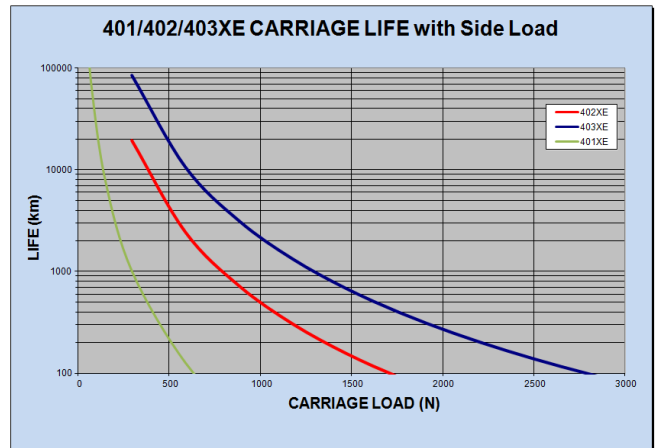
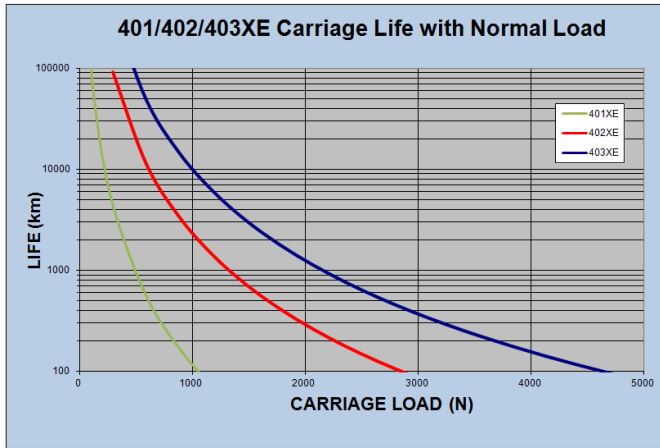

Technical Data - 401/402/403XE

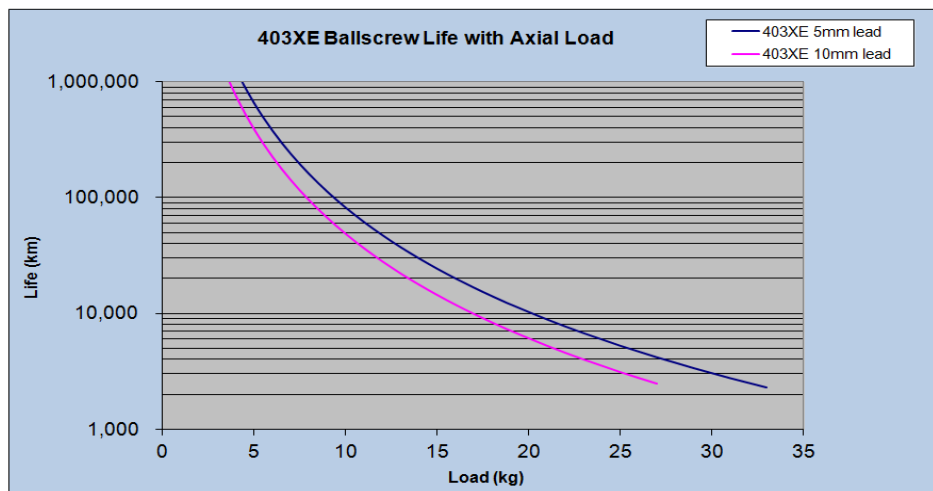
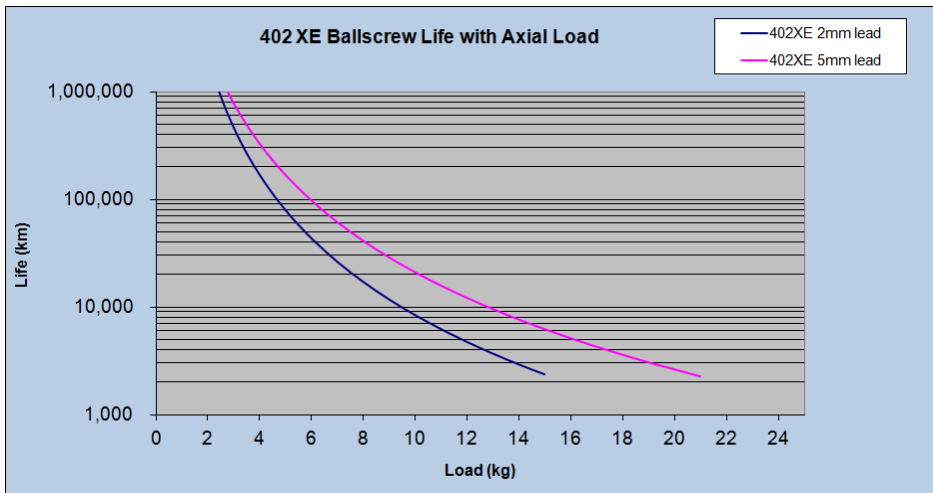
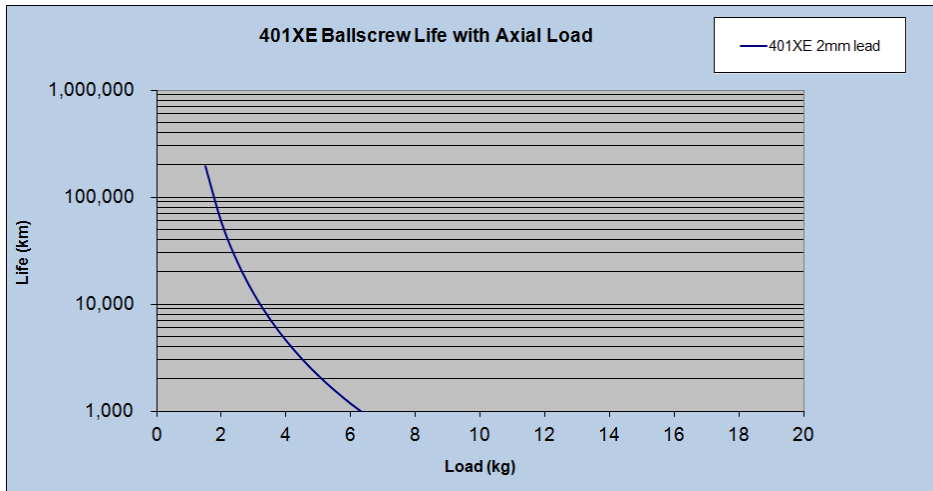

Clean Room Preparation

There is no cleanroom “rating” for motion control products, just individual compatibility with class of cleanrooms. The compatibility is also dependent on measurement location. A point directly below a component may have a different particle count than at a side location. Cleanroom class compatibility information for 401/402/403XE tables with cleanroom preparation (R12 & R14 option) is not available at the time of publication of this product manual. Consult factory for details and cleanroom class compatibility expectations for specific applications.

Standard Cleanroom Preparation:

Stringent cleaning and handling measures

Cleanroom rated lubricant

Raydent coating on 401XE, 402XE and 403XE positioners

Chapter 3 - Component Specifications

Motor Information

The M* motor options supply a Parker servo or stepper motor assembled to the positioner. For specifications and setup and connection parameters, refer to the motor user guides available for download from www.parkermotion.com.

Limit/Home Switch Information - 401/402/403XE

The limit/home switch installed on the 401XE,402XE and 403XE is a hall effect sensor tripped by a magnet located in a housing attached to the carriage. On the switch body is an LED to indicate activation. Normally open (N.O.), normally closed (N.C.), current sinking (NPN) and current sourcing (PNP) variations are selectable with the product. Normally open sensors are typically used for home and normally closed are typically used for limits. With a current sinking sensor, the output lead provides a path to ground when activated, and with a current sourcing sensor, the output lead provides a positive (+) voltage potential relative to ground. Refer to your controller's manual for compatibility. Limit/home switch information is below.



401/402/403XE Limit/Home Switch Specifications

	HA or LA Option	HB or LB Option	HC or LC Option	HD or LD Option
Switch Type	N.C.	N.O.	N.C.	N.O.
Logic	NPN	NPN	PNP	PNP
Operating Voltage	10-30 VDC			
Voltage Drop	2.5 VDC Max			
Continuous Current	100 mA			
Repeatability	100 μ m Max			
Reverse Polarity Protection	Yes			
Short Circuit Protection	Yes			
Power-Up Pulse Suppression	Yes			
Enclosure Rating	IP67			
Operating Temperature Range	-25°C to +75°C			
Cable Length	3.0 m from Switch			

401/402/403XE Limit/Home Switch Wiring Code

Power (+)	Brown
Output Signal	Black
Ground (-)	Blue

Coupling Information

Standard coupling offerings include standard grade Oldham style and precision grade bellows style. Coupling information is below. See Appendix A for coupling part numbers.

401XE Coupling Specifications

Coupling Option	Style	Bore Diameter (Motor Shaft)	Outside Diameter - mm (in)	Length - mm (in)	Rated Torque - Nm	Torsional Stiffness - $\frac{\circ}{\text{Nm}}$	Misalignment			Clamp Screw Torque - in-lb
							Radial	Axial	Angular	
C1	No coupler	-	-	-	-	-	-	-	-	-
C3	Bellows	.25 in.	20.0 (0.79)	26.0 (1.02)	1.5	0.076	+/-0.10 mm	+/-0.25 mm	+/-1.2°	7
C7	Bellows	5 mm	20.0 (0.79)	26.0 (1.02)	1.5	0.076	+/-0.10 mm	+/-0.25 mm	+/-1.2°	7

402XE Coupling Specifications

Coupling Option	Style	Bore Diameter (Motor Shaft)	Outside Diameter - mm (in)	Length - mm (in)	Rated Torque - Nm	Torsional Stiffness - $\frac{\circ}{\text{Nm}}$	Misalignment			Clamp Screw Torque - in-lb
							Radial	Axial	Angular	
C1	No coupler	-	-	-	-	-	-	-	-	-
C2	Oldham	.25 in.	19.1 (0.75)	25.4 (1.00)	2.25	0.38	+/-0.20 mm	+/-0.10 mm	+/-0.5°	11
C3	Bellows	.25 in.	20.0 (0.79)	26.0 (1.02)	1.5	0.076	+/-0.10 mm	+/-0.25 mm	+/-1.2°	7
C5	Bellows	.375 in.	20.0 (0.79)	26.0 (1.02)	1.5	0.076	+/-0.10 mm	+/-0.25 mm	+/-1.2°	7
C6	Oldham	5 mm	19.1 (0.75)	25.4 (1.00)	2.25	0.38	+/-0.20 mm	+/-0.10 mm	+/-0.5°	11
C7	Bellows	5 mm	20.0 (0.79)	26.0 (1.02)	1.5	0.076	+/-0.10 mm	+/-0.25 mm	+/-1.2°	7
C8	Oldham	8 mm	19.1 (0.75)	25.4 (1.00)	2.25	0.38	+/-0.20 mm	+/-0.10 mm	+/-0.5°	11
C9	Bellows	8 mm	20.0 (0.79)	26.0 (1.02)	1.5	0.076	+/-0.10 mm	+/-0.25 mm	+/-1.2°	7

403XE Coupling Specifications

Coupling Option	Style	Bore Diameter (Motor Shaft)	Outside Diameter - mm (in)	Length - mm (in)	Rated Torque - Nm	Torsional Stiffness - $\frac{\circ}{\text{Nm}}$	Misalignment			Clamp Screw Torque - in-lb
							Radial	Axial	Angular	
C1	No coupler	-	-	-	-	-	-	-	-	-
C2	Oldham	.25 in.	25.4 (1.00)	31.8 (1.25)	4.75	0.291	+/-0.20 mm	+/-0.10 mm	+/-0.5°	19
C3	Bellows	.25 in.	20.0 (0.79)	26.0 (1.02)	1.5	0.076	+/-0.10 mm	+/-0.25 mm	+/-1.2°	7
C4	Oldham	.375 in.	25.4 (1.00)	31.8 (1.25)	4.75	0.291	+/-0.20 mm	+/-0.10 mm	+/-0.5°	19
C5	Bellows	.375 in.	20.0 (0.79)	26.0 (1.02)	1.5	0.076	+/-0.10 mm	+/-0.25 mm	+/-1.2°	7
C6	Oldham	5 mm	19.1 (0.75)	25.4 (1.00)	2.25	0.38	+/-0.20 mm	+/-0.10 mm	+/-0.5°	11
C7	Bellows	5 mm	20.0 (0.79)	26.0 (1.02)	1.5	0.076	+/-0.10 mm	+/-0.25 mm	+/-1.2°	7
C8	Oldham	8 mm	19.1 (0.75)	25.4 (1.00)	2.25	0.38	+/-0.20 mm	+/-0.10 mm	+/-0.5°	11
C9	Bellows	8 mm	20.0 (0.79)	26.0 (1.02)	1.5	0.076	+/-0.10 mm	+/-0.25 mm	+/-1.2°	7

Chapter 4 - Setup and Usage

Mounting Orientation

The 401/402/403XE positioner can be mounted in a normal, side, vertical, or inverted orientation. For vertical (Z axis) mounting, care must be taken since certain ballscrew and load combinations can backdrive in a power loss situation. For all orientations, the cables should be secured as to not interfere with the movement of the carriage.

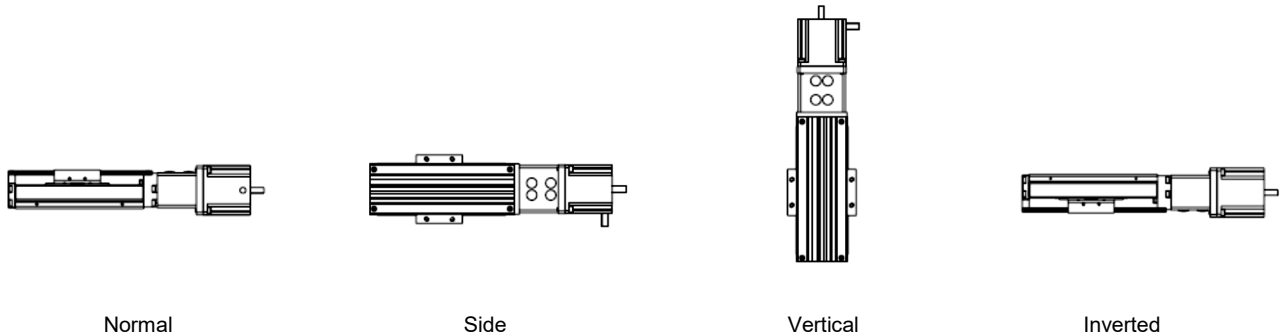

Mounting Surface Requirements

Proper mounting of the 401/402/403XE positioner is essential to optimize product performance. All specifications are based on the following conditions:

- The positioner must be bolted down along its entire length.
- The positioner must be mounted to a flat, stable surface with flatness error less than or equal to 0.013mm/300mm (0.0005"/ft).
- Catalog specifications may deviate for a positioner mounted to a surface that does not meet the above conditions.
- If the surface does not meet the above conditions the surface may be shimmed to comply with these requirements.
- If mounting conditions require that the table base be overhung, catalog specifications will not be met over that portion of the table. Additionally, in X-Y systems the overhung portion of the Y axis may not meet specifications due to the additional error caused by deflection of the unsupported base. Contact factory for guidelines on specifications of overhung applications.

Base Through Hole Mounting - 401/402/403XE

The 401XE, 402XE and 403XE have counterbored clearance holes in the base of the unit for mounting. To properly mount the positioner along its entire length, it is required that all counterbored holes be used. See Chapter 2 for hole location and size.

If equipped with a hard cover (R1 option), the cover needs to be removed to access the holes. To do so, use a 2.0mm hex wrench to remove the two button head screws at each end of the cover.

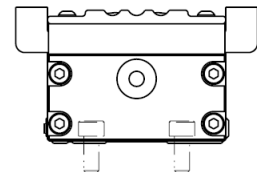

Riser Plates

Most of the motors used with the 401/402/403XE have a taller profile than the positioner. Thus the motor can interfere with the positioner mounting surface. To accommodate taller motors, riser plates can be provided to space the unit above the mounting surface. See Appendix A for riser plate drawings and part numbers.

Payload Mounting

Payload is mounted to the 401/402/403XE using four tapped holes in the carriage. When fastening to the carriage, take precaution in using screws with no more than 6mm of engagement for the 401XE, 13mm of engagement for the 402XE, and 15mm of engagement for the 403XE as to not damage the positioner. See Chapter 2 for hole sizes and locations.

Accessory transition plates are available to build X-Y configurations with various table combinations. If doing so, be certain not to exceed the moment load specifications outlined in Chapter 2. See Appendix A for transition plate drawings and part numbers.



Use Appropriate Length Bolt

The 401/402/403XE design requires proper size bolts to be used when mounting payloads to the carriage. Excessive length bolts can cause damage or pin the table in position.

Inline Motor Mounting

Follow the below procedure to install an inline motor to the 401/402/403XE linear positioner.

Tools Required: 2.0mm, 2.5mm, 3.0mm, and 4.0mm Hex Wrenches, Torque Wrench, Loctite 242 or Equivalent

Step 1: Slide coupling onto positioner drive screw shaft and tighten the clamp screw. See Chapter 3 for coupling clamp screw torque specifications. DO NOT use Loctite on coupling screws.

Step 2: Mount motor to motor adapter using appropriate hardware, making sure motor shaft engages coupling bore. Apply Loctite 242 to mounting screw threads prior to assembly.

Step 3: Tighten coupling clamp screw on motor shaft side. See Chapter 3 for coupling clamp screw torque specifications. DO NOT use Loctite on coupling screws. If motor has a rear shaft, rotate motor by rear shaft and check that carriage moves. Hold carriage and attempt to rotate motor by rear shaft to check that coupling does not slip.

Parallel Motor Mounting - 401/402/403XE

Follow the below procedure to install the parallel motor mount and motor to the 401/402/403XE linear positioner.

Tools Required: 2.0mm, 2.5mm, 3.0mm, and 4.0mm Hex Wrenches, Torque Wrench, Depth Micrometer, Force Gauge, Loctite 609 and 242 or Equivalent

Step 1: Identify the desired parallel mounting position "A", "B", or "C".

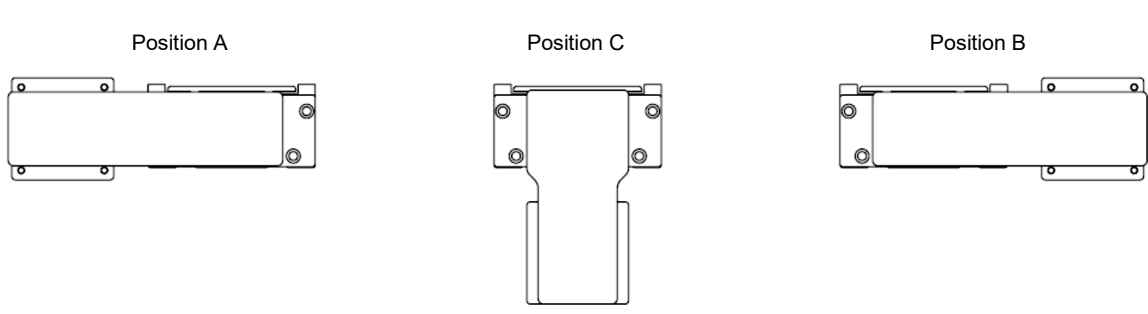

Step 2: Remove any motor, coupling, adapter plate, and motor block previously installed on positioner.

Step 3: IF USING MOTOR POSITION “A” OR “B”: Locate parallel mount components for side positions:
 IF USING MOTOR POSITION “C”: Locate parallel mount components for bottom position:

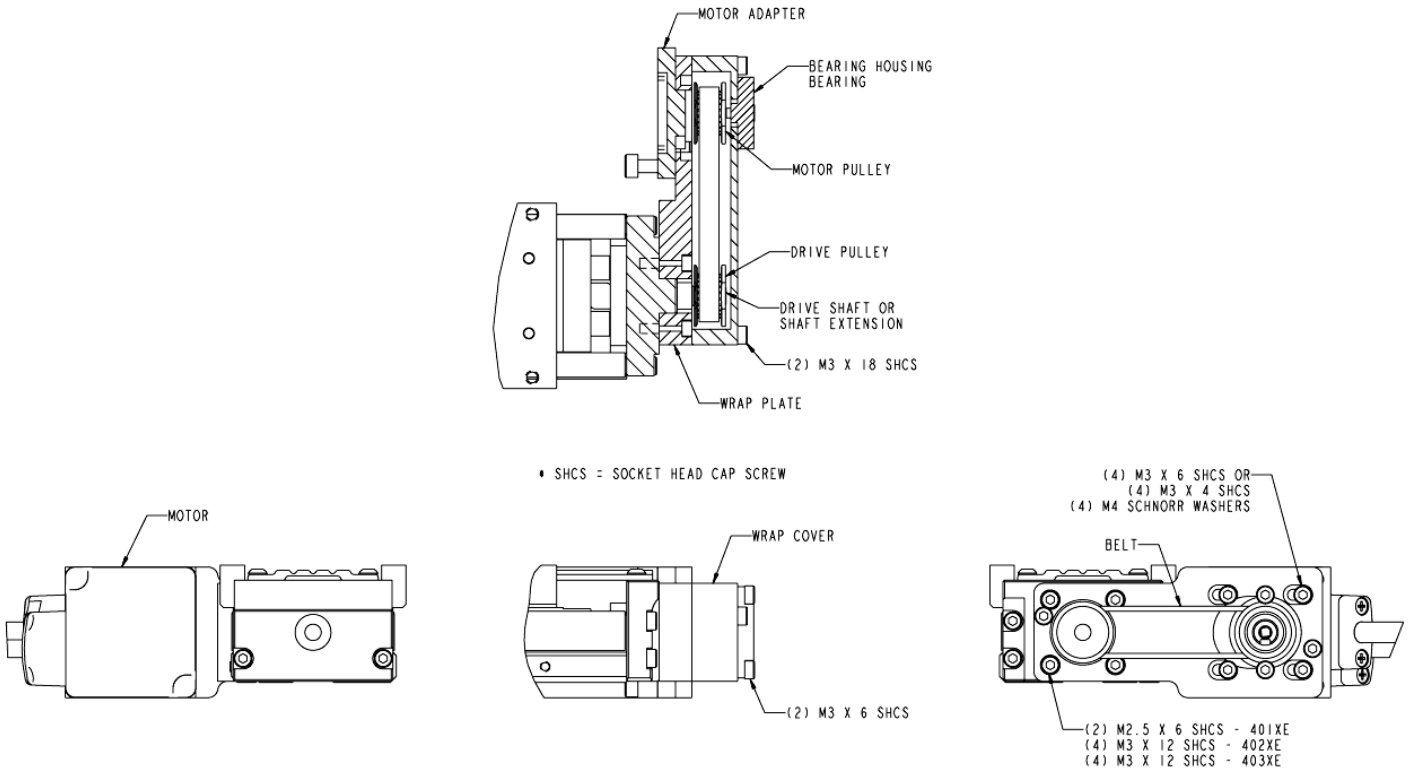

Step 4: Apply Loctite 609 to positioner drive screw shaft. Mount pulley, with clamp collar, to screw shaft by sliding it onto the shaft until it contacts the locknut. Tighten clamp screw to 13in-lb.

Step 5: Place shroud, (less cover plate) over pulley onto positioner in desired orientation. For side positions “A” and “B” install and tighten two (2) socket head cap screws, through the deep counterbored holes and install and tighten two (2) button head screws, through the remaining holes. For bottom position “C” install and tighten four (4) socket head cap screws, through the deep counterbored holes. Prior to assembly apply Loctite 242 to the screw threads.

Step 6: Using depth micrometer, measure distance from the open face of the shroud to the face of the pulley flange. The pulley should be recessed some distance from the open face of the shroud. Record this distance.

Step 7: Mount motor adapter plate, to motor flange using appropriate hardware. Note the motor side of the adapter plate is piloted for the motor. Apply Loctite 242 to screw threads prior to assembly. IT IS CRITICAL that the mounting screws do not protrude through the adapter plate.

Step 8: Apply Loctite 609 to motor shaft and loosely mount pulley, with clamp collar, to motor shaft. Place motor/adaptor plate assembly against shroud in the mounting position and measure the distance from the open face of the shroud to the face of the pulley. The pulley recess distance should match the distance recorded earlier. Readjust until the distance is matched and tighten clamp screw to 13in-lb. Note once the Loctite 609 is applied, this step should be completed within 10 minutes.

Step 9: Place drive belt over drive screw shaft pulley.

Step 10: Place motor/adaptor plate assembly against shroud and place belt over motor pulley. Loosely install four (4) button head screws with four (4) spring washers. IT IS CRITICAL that the correct length bolts be used.

Step 11: Tension drive belt by applying a side force of 4 lbs to the motor and tighten the mounting screws. Manually traverse the positioner back and forth while observing the belt. The belt should ride in the center of the pulley surfaces (between the flanges). If the belt continually runs against one side of the pulley then alignment needs to be readjusted.

Step 12: Mount cover plate using four (4) button head screws.

Limit/Home Switch Adjustment - 401/402/403XE

Travel limit sensors signal the motor to stop whenever the carriage is approaching the end of travel. The home sensor provides a fixed reference point to which the carriage can be commanded to return repeatedly.

If equipped, the 401XE, 402XE and 403XE limit switches are set at the factory at the ends of travel and the home switch is set at the center of travel. To adjust the switches, loosen the screw that secures the switch into the slot with a flat blade screw driver, slide the switch into the desired position, and retighten.

Printed on the body of the switch is a target (crosshairs). 402XE limit switch settings to utilize full travel are 44mm and 45mm from the target centerline to the end block for the motor and idler locations, respectively. 403XE limit switch settings to utilize full travel are 58mm and 52mm from the target centerline to the end block for the motor and idler locations, respectively.

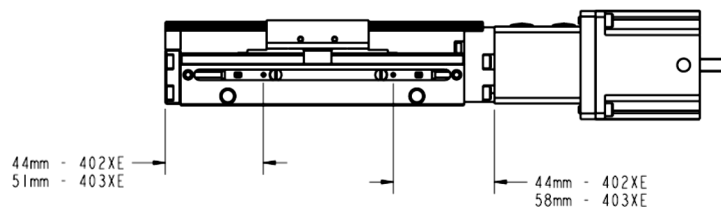

Chapter 5 - Maintenance and Repair

Linear Bearing & Ballscrew Lubrication - 401/402/403XE

Lubrication Type:

FOR STANDARD PREPARATION : Use *Kyodo Yushi Multemp PS#2*. Contact Kyodo Yushi at +1-630-595-2020 or www.kyodoyushi.co.jp/eng/ for additional technical information, direct purchase or local distributor information.

Lubricant Appearance:

FOR STANDARD PREPARATION: *Multemp PS#2* - Off-white, smooth but slightly tacky.

Maintenance Frequency:

FOR BOTH STANDARD : Linear bearings and ballscrews are lubricated at the factory prior to shipment. For lubrication inspection and supply intervals following shipment, apply grease every 1000 hours of usage. The time period may change depending on frequency of use and environment. Inspect for contamination, chips, etc., and replenish according to inspection results.

Lubricant Application:

FOR BOTH STANDARD : Remove hard cover if equipped. Wipe down the bearing guides and screw the entire length with a clean cloth. Apply one pump of lubricant to the grease nipple on the carriage assembly to supply lubricant to the linear bearings. With a small brush apply lubricant on the screw. Traverse the table and repeat if needed.

Notes:

Do not use/mix petroleum base grease with synthetic base grease at any time. For lubrication under special conditions consult factory.

Shorter lubrication interval may be required in environments with high amounts of dust and other contamination.

Appendix A - Accessories & Spare Parts

Part Number	Description
002-2975-01	Transition plate kit, 401XE Y axis to 401XE X axis
002-2976-01	Transition plate kit, 401XE Y axis to 402XE X axis
002-2977-01	Transition plate kit, 401XE Y axis to 403XE X axis
002-1378-05	402XE Coupling, 5mm Bore Oldham
002-1378-07	403XE Coupling, 5mm Bore Oldham
002-1378-09	402XE Coupling, 0.25" Bore Oldham
002-1412-10	403XE Coupling, 0.375" Bore Oldham
002-1412-22	403XE Coupling, 0.25" Bore Oldham
002-2817-01	403XE Riser Plate Kit - Includes Plate and Hardware
002-2818-01	402XE Riser Plate Kit - Includes Plate and Hardware
002-2819-01	Transition Plate Kit, 402T01XE Y Axis, 402XE X Axis - Includes Plate and Hardware
002-2820-01	Transition Plate Kit, 402T02XE to 402T04XE Y Axis, 402XE X Axis - Includes Plate and Hardware
002-2821-01	Transition Plate Kit, 402T01XE or 403T01XE Y Axis, 403XE X Axis - Includes Plate and Hardware
002-2822-01	Transition Plate Kit, 402T02XE to 402T04XE or 403T02XE to 403T08XE Y Axis, 403XE X Axis - Includes Plate and Hardware
002-2823-01	Transition Plate Kit, 402XE or 403XE Y Axis, 404XE X Axis - Includes Plate and Hardware
003-1898-76	403XE Coupling, 0.25" Bore Bellows
003-1898-126	402XE Coupling, 0.25" Bore Bellows
003-1898-132	402XE Coupling, 0.375" Bore Bellows
003-1898-133	403XE Coupling, 0.375" Bore Bellows
003-1898-137	402XE Coupling, 5mm Bore Bellows
003-1898-138	403XE Coupling, 5mm Bore Bellows
003-1898-162	401XE Coupling, .25 in. Bore Bellows
003-1898-167	401XE Coupling, 5 mm Bore Bellows

See Chapter 2 for motor adapter drawings.

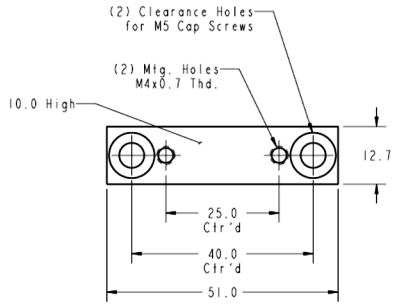

002-2818-01 402XE Riser Plate

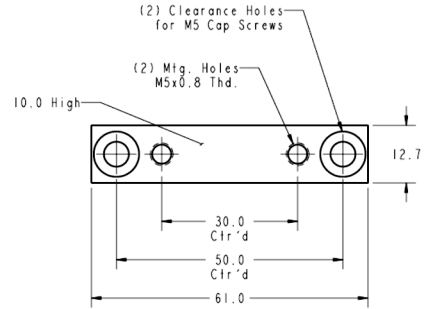

002-2817-01 403XE Riser Plate

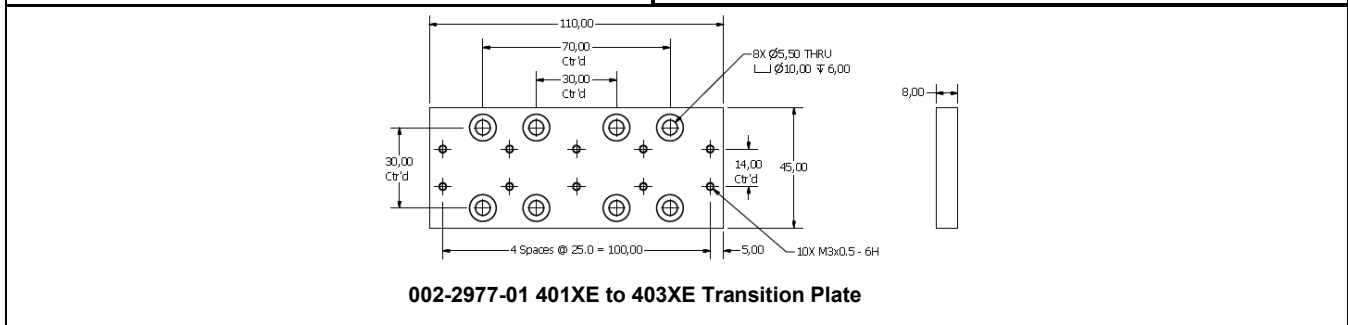
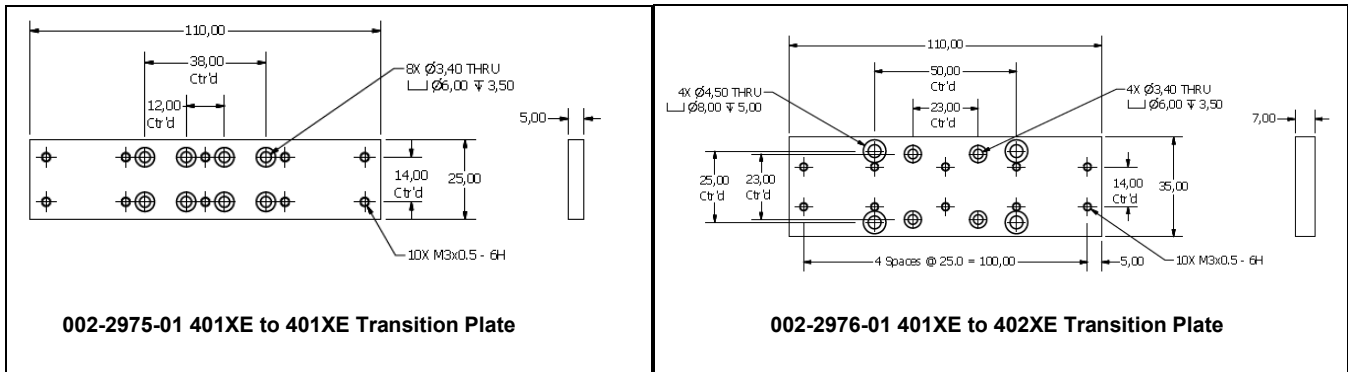

X Axis	Y Axis	Part Number	"A"	"B"	"C"	"D"	"E"	"F"
402XE	402T01XE	002-2819-01	120.0	17.5	1	80.0	80.0	4
402XE	402T02XE to 402T04XE	002-2820-01	180.0	7.5	4	40.0	160.0	10

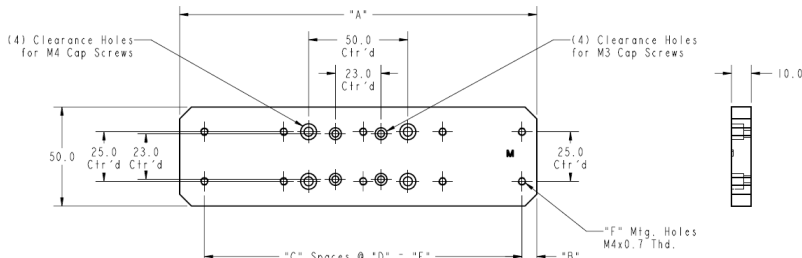

X Axis	Y Axis	Part Number	"A"	"B"	"C"	"D"	"E"	"F"	"G"	"H"
403XE	402T01XE or 403T01XE	002-2821-01	120.0	7.5	1	100.0	100.0	4	32.5	80.0
403XE	402T02XE to 402T04XE or 403T02XE to 403T08XE	002-2822-01	211.0	3.0	4	50.0	200.0	10	23.0	160.0

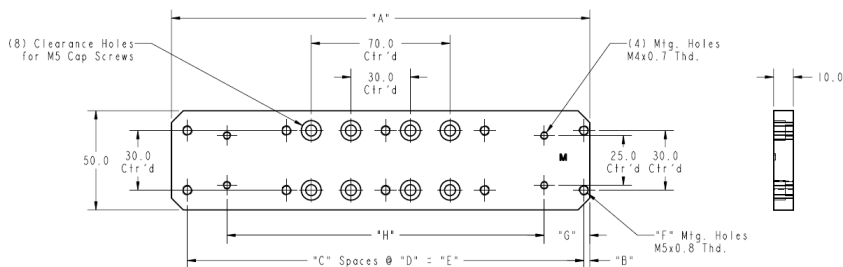

Appendix B - Internal Protection

Parker has conducted testing to determine the *degree* to which the positioner is protected by using a British standard called an **Ingress Protection Rating (IP Rating)**. The 402XE and 403XE have an IP 20 protection rating when equipped with hard cover (R1 option).

Definition

Reference: British standard EN 60529 : 1992

This standard describes a system of classifying degrees of protection provided by enclosures of electrical equipment. Standardized test methods and the establishment of a two digit numeric rating verify the extent of protection provided against access to hazardous parts, against ingress of solid foreign objects, and against the ingress of water.

First Number: The first number indicates protection of persons against access to dangerous parts and protection of internal equipment against the ingress of solid foreign objects.

- 1 - Protection against access to hazardous parts with the back of a hand, and protected against solid foreign objects of 50 mm diameter and larger.
- 2 - Protection against access to hazardous parts with fingers, and protected against solid foreign objects of 12.5 mm diameter and larger.
- 3 - Protection against access to hazardous parts with a tool, and protected against solid foreign objects of 2.5 mm diameter and larger.

Second Number: The second number indicates protection of internal equipment against harmful ingress of water.

- 0 - No special protection provided.

Note: Number indicators above represent only a partial list of IP Rating specifications.

Appendix C - Compliance Documentation



RoHS Compliance Statement

We hereby certify that the 401/402/403XE product line, produced by Parker Hannifin Corporation, complies with the requirements of the EU Directive 2011/65/EU on the restriction of the use of certain hazardous substances (RoHS) and other national and international legislation similarly restricting the use of materials.

Substance	Threshold
Cadmium (Cd) and its compounds	.01%
Mercury and its compounds	.1%
Lead (Pb) and its compounds	.1%
Hexavalent Chromium (Cr6+)	.1%
Polybrominated biphenyls (PBB)	.1%
Polybrominated diphenyl ethers (PBDE)	.1%



DECLARATION OF INCORPORATION

ACCORDING TO EC DIRECTIVE 2006/42/EC (ANNEX II, PART 1, SECTION B) FOR PARTLY COMPLETED MACHINERIES

The above mentioned Manufacturer/Authorized person declare that the product is complying with the following essential requirements of the machinery directive 2006/42/EC.

Annex 1, Article 1.1.1, 1.1.2, 1.1.3, 1.1.5, 1.3.1, 1.3.2, 1.3.3, 1.3.4, 1.3.7, 1.4.1, 1.5.4, 1.5.8, 1.6.1

EN ISO 12100 1,2	Safety of Machinery – basic concepts. Part 1: Fundamental terminology, methodology
EN 349	Safety of machinery - Minimum gaps to avoid crushing of parts of the human body
EN ISO 13857	Safety of machinery - Safety distances to prevent hazard zones being reached by upper and lower limbs
EN/IEC 60204-1	Safety of machinery - Electrical equipment of machines - Part 1: general requirements



anything **Parker**
Possible.™

Parker Hannifin Corporation
Electromechanical Automation Division
1140 Sandy Hill Road
Irwin, PA 15642
Tel: (800) 245-6906
www.parkermotion.com
Email: emn_sales@parker.com
emn_support@parker.com

