

OSPE..SB/ST Screw-Driven Actuators

OSPE..SB Ball Screw Actuators for Precise Positioning

OSPE..ST Trapezoidal Screw Actuators for Zero Backdrive

- Medium precise and highly repeatable position control
- High thrust force output
- Easy installation
- Excellent low speed characteristics
- No back-drive with OSPE..ST
- Integrated drive train and glider bearing
- Complete motor, gearhead and control packages
- Diverse range of accessories and mountings
- Clean room option on request
- Ambient temperature range -20°C to +80°C
- IP54 rated



EXTERNAL GUIDE BEARING OPTIONS:

PowerSlide

- Designed for harsh environments
- Hardened steel guide rail
- Carriage with steel v-wheels
- Tough roller cover with wiper and grease access point

ProLine

- Designed for high-speed, precise, smooth and quiet operation
- Aluminum rail with ground and calibrated steel trucks
- Carriage supported by needle bearing rolls
- Integrated wipers to keep bearing system clean
- Lifetime lubricated bearing system

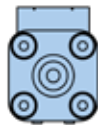

OSPE-25SB/ST

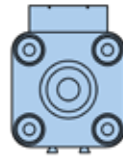

OSPE-32SB/ST

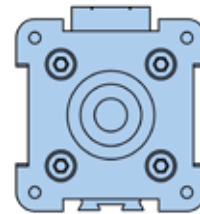

OSPE-50SB/ST

	OSPE 25SB	OSPE 32SB	OSPE 50SB	OSPE 25ST	OSPE 32ST	OSPE 50ST
Maximum Travel (mm)	1000	2000	3200	1000	2000	2400
Maximum Payload (N)	500	1200	3000	500	1000	1500
Maximum Acceleration (m/s²)	10	10	10	2	2	2

* SB = Ball Screw, ST = Trapezoidal Screw

** Does not include external guide rail in values

The field-proven OSPE..SB/ST design is the industry standard for medium precise positioning with a ball screw or intermittent duty positioning without back-drive with a trapezoidal screw. Compact size and maximum configurability make the OSPE..SB/ST easy to integrate into any machine layout simply and neatly.

The OSPE..SB design utilizes a ball screw which is ideal for medium precise applications requiring a 50 micron unidirectional repeatability. A ball screw is used in machines requiring reliable positioning with continuous and medium to high thrust force output at 100% duty cycle.

The OSPE..ST design utilizes a trapezoidal screw, which is ideal for low-speed and high-thrust applications with a maximum duty cycle of 10%. The trapezoidal screw has no back drive and therefore can hold loads in position without a motor brake, even in vertical orientations.

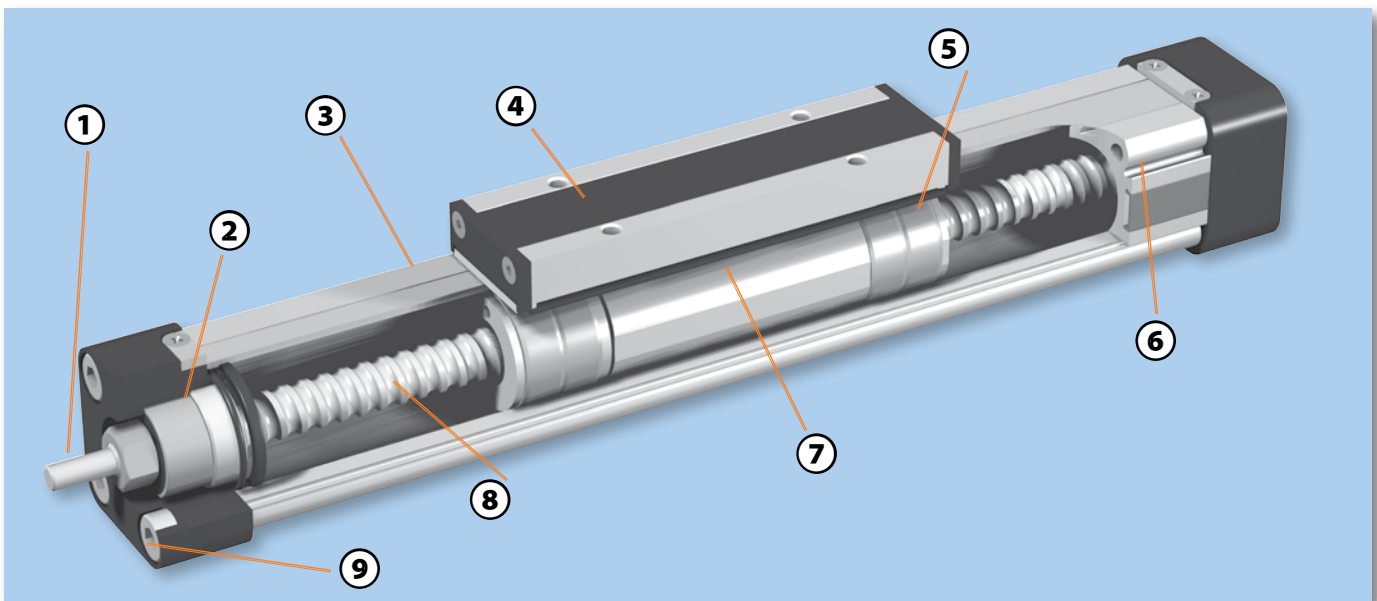

- ① Drive shaft**
Designed to pair with a large assortment of motor and gearhead mounting options
- ② Double row angular contact ball bearing**
Optimized for high thrust force transmission
- ③ Corrosion resistant steel sealing band**
Magnetically fastened to the actuator body and provides sealing to IP54
- ④ Carriage**
Low profile, high strength aluminum carriage with threaded holes for ease of mounting
- ⑤ Low friction support rings**
Polymer glider bushing to provide an economical guidance system with optimum performance
- ⑥ Slotted profile**
With dovetail grooves for strength, actuator mounting, and mounting of sensor and other accessories
- ⑦ Fastening**
SB actuators with hardened ball screw nut; ST actuators with low friction plastic nut
- ⑧ Lead screw**
Ball screw or trapezoidal
- ⑨ End housing mounting**
Threaded mounting holes allow for a multitude of mounting options

Carriage Options

Standard or Tandem carriage — for higher load capabilities (OSPE..SB only)



Actuator Mounting Options

End cap mounting — allows actuator to be anchored by the end caps
Profile mounting — supports long travel actuators or for direct mounting (as shown)



Carriage Bearing Design Configurations

Standard carriage (with internal glider bearing), PowerSlide (externally mounted steel roller guide for higher load capabilities specifically in harsh environments), and ProLine (externally mounted aluminum roller guide for higher load capabilities and precision positioning)



Carriage Mounting

Standard, clevis (provides compensation between actuator and external guide rails in machine designs), and Inversion mounting (allows outer band to be on the bottom, while keeping payload on top, for better actuator protection in dirty environments)



Market Specific Options

Cleanroom version — Specific scraper system and vacuum suction ports to operate in clean environments (OSPE..SB only). Certified according to DIN EN ISO 146441-1. Please consult factory for more information.

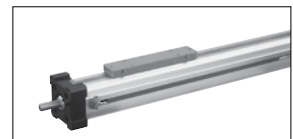

Multi-axis Systems

A wide range of adapter plates and intermediate drive shafts simplifies engineering and installation. Please consult factory for your individual system design.

Options and Accessories

Information on all OSPE..SB/ST Series options are detailed in Options & Accessories. Simply select all the options needed to solve your application requirements, then order with the actuator using convenient order codes (see Ordering Information). To order an option separately as an upgrade to an existing system or as a replacement part, use the individual option part numbers provided.

SPECIFICATIONS

OSPE..SB/ST General Specifications

Actuator Size			OSPE25		OSPE32			OSPE50			
Screw Type (SB-Ball; ST-Trapezoidal)			SB	ST	SB	SB	ST	SB	SB	SB	ST
Screw Lead	s_{lin}	mm	5	4	5	10	4	5	10	25	6
Screw diameter		mm	12	16	16	16	20	25	25	25	30
Duty cycle*		%	100	10	100	100	10	100	100	100	10
Efficiency	η	%	90	40	90	90	40	90	90	90	40
Linear Speed (Max)	v_{max}	mm/s	250	100	250	500	100	250	500	1,250	150
Radial Speed (Max)		rpm	3,000	1,500	3,000	3,000	1,500	3,000	3,000	3,000	1,500
Acceleration (Max)	a_{max}	m/s ²	2	2	2	4	2	2	4	10	2
Repeatability (unidirectional)		μ m	± 50	± 500	± 50	± 50	± 500	± 50	± 50	± 50	± 500
Thrust Force (Max)	F_{Amax}	N	250	600	1,100	800	1,300	1,300	1,450	1,350	2,500
		lbs	56	135	247	180	292	292	326	303	562
Torque on Drive Shaft (Max)	M_{Amax}	Nm	0.4	1.3	1.2	1.7	2.5	1.5	3.1	6.7	6.6
		in-lb	3.7	11.1	10.4	15.2	21.9	13.7	27.1	59.0	58.1
Inertia											
@ Zero Stroke	J_0	kgmm ²	2	6	8	8	22	84	84	84	152
Per Meter of Stroke	J_{OS}	kgmm ² /m	11.0	30.0	32.0	32.0	81.0	225.0	225.0	225.0	400.0
Per 1 kg Moved Mass	J_m	kgmm ² /kg	0.6	0.4	0.6	2.5	0.4	0.6	2.5	15.8	0.9
Ambient Temperature Range		°C	-20 to +80 (OSPE..SB); -20 to +70 (OSPE..ST)								
IP Rating			IP54								

* Due to the friction between the plastic nut and trapezoidal screw, the duty cycle must not exceed 10% to avoid early wear and increased noise emission.

Calculating Load Factors - Combined Normal and Moment Load

The sum of combined loads (static and dynamic) must not exceed “1” at any time as shown in the formula below:

$$\frac{F_z}{F_z \text{ (max)}} + \frac{M_x}{M_x \text{ (max)}} + \frac{M_y}{M_y \text{ (max)}} + \frac{M_z}{M_z \text{ (max)}} \leq 1$$



$M = F \times l$ (Nm)
 $M_x = M_{x \text{ static}} + M_{x \text{ dynamic}}$
 $M_y = M_{y \text{ static}} + M_{y \text{ dynamic}}$
 $M_z = M_{z \text{ static}} + M_{z \text{ dynamic}}$

OSPE25SB/ST Performance

Carriage (Bearing System)			Standard Carriage		PowerSlide			ProLine
			SB	ST	PS25/25	PS25/35	PS25/44	PL32
Part Number ¹			—	—	20015	20016	20017	20856
Max Order Stroke ²	OS_{max}	mm	1100	1100	1100	1100	1100	1100
Normal Load ³ (Max)	F_Y / F_Z	N (lbs)	500 (112)	500 (112)	297 (67)	330 (74)	575 (129)	1236 (278)
	M_x		2 (18)	2 (18)	5 (44)	6 (53)	10 (89)	24 (212)
	M_y	Nm (in-lb)	12 (106)	24 (212)	21 (186)	23 (204)	85 (752)	55 (487)
Moment Load ³ (Max)	M_z		8 (71)	7 (62)	21 (186)	23 (204)	85 (752)	55 (487)
	M_0	Nm (in-lb)	0.2 (1.8)	—	0.3 (2.7)	0.3 (2.7)	0.3 (2.7)	0.3 (2.7)
Torque — SB – 5 mm lead No Load ⁴ ST – 4 mm lead	M_0		—	0.3 (2.7)	0.4 (3.5)	0.4 (3.5)	0.4 (3.5)	0.4 (3.5)
	m_0		0.6 (1.32)	—	0.9 (1.98)	1.0 (2.20)	1.2 (2.64)	0.8 (1.76)
Weight	SB Per Meter of Stroke	m_{OS}	2.3 (5.06)	—	3.7 (8.14)	4.1 (9.02)	4.9 (10.78)	4.0 (8.80)
	Carriage ⁴	m_C	0.2 (0.44)	—	0.9 (1.98)	1.0 (2.20)	1.7 (3.74)	1.0 (2.20)
Weight	@ 0 Stroke	m_0	—	0.7 (1.54)	1.0 (2.20)	1.1 (2.42)	1.3 (2.86)	0.9 (1.98)
	ST Per Meter of Stroke	m_{OS}	—	1.6 (3.52)	4.2 (9.24)	4.6 (10.12)	5.4 (11.88)	4.5 (9.90)
Weight	Carriage ⁴	m_C	—	0.2 (0.44)	0.9 (1.98)	1.0 (2.20)	1.7 (3.74)	1.0 (2.20)

OSPE32SB/ST Performance

Carriage (Bearing System)			Standard Carriage		PowerSlide		ProLine	
			SB	ST	PS32/35	PS32/44	PL32	
Part Number ¹			—	—	20286	20287	20857	
Max Order Stroke ²		OS _{max} mm	2000	2000	2000	2000	2000	
Normal Load ³ (Max)		F _Y /F _Z N (lbs)	1200 (270)	1000 (225)	458 (103)	1111 (250)	1689 (380)	
Moment Load ³ (Max)		M _X	8 (71)	6 (53)	7 (62)	24 (212)	41 (363)	
		M _Y Nm (in-lb)	25 (221)	65 (575)	23 (204)	85 (752)	105 (929)	
		M _Z	16 (142)	12 (106)	23 (204)	85 (752)	105 (929)	
Torque — No Load ⁴		SB – 5 mm lead	M ₀	0.3 (2.7)	—	0.4 (3.5)	0.4 (3.5)	0.4 (3.5)
		SB – 10 mm lead	M ₀ Nm (in-lb)	0.4 (3.5)	—	0.5 (4.4)	0.5 (4.4)	0.5 (4.4)
		ST – 4 mm lead	M ₀	—	0.6 (5.3)	0.7 (6.2)	0.7 (6.2)	0.7 (6.2)
Weight	SB	@ 0 Stroke	m ₀	1.6 (3.52)	—	2.0 (4.40)	2.2 (4.84)	2.1 (4.62)
		Per Meter of Stroke	m _{OS}	4.4 (9.68)	—	6.3 (13.86)	7.0 (15.40)	7.0 (15.40)
		Carriage ⁴	m _C kg (lbs)	0.4 (0.88)	—	1.2 (2.64)	1.9 (4.18)	1.6 (3.52)
	ST	@ 0 Stroke	m ₀	—	1.6 (3.52)	2.6 (5.72)	2.8 (6.16)	2.1 (4.62)
		Per Meter of Stroke	m _{OS}	—	5.0 (11.00)	6.9 (15.18)	7.6 (16.72)	7.6 (16.72)
		Carriage ⁴	m _C	—	0.5 (1.10)	1.3 (2.86)	2.0 (4.40)	1.7 (3.74)

OSPE50SB/ST Performance

Carriage (Bearing System)			Standard Carriage		PowerSlide		ProLine	
			SB	ST	PS50/60	PS50/76	PL50	
Part Number ¹			—	—	20288	20289	20859	
Max Order Stroke ²		OS _{max} mm	2000	2000	2000	2000	2000	
Normal Load ³ (Max)		F _Y /F _Z N (lbs)	3000 (674)	1500 (337)	1449 (326)	2518 (566)	4489 (1009)	
Moment Load ³ (Max)		M _X	16 (142)	13 (115)	43 (381)	88 (779)	160 (1416)	
		M _Y Nm (in-lb)	80 (708)	155 (1372)	121 (1071)	220 (1947)	360 (3186)	
		M _Z	32 (283)	26 (230)	121 (1071)	220 (1947)	360 (3186)	
Torque — No Load ⁴		SB – 5 mm lead	M ₀	0.6 (5.3)	—	0.8 (7.1)	0.8 (7.1)	0.8 (7.1)
		SB – 10 mm lead	M ₀ Nm (in-lb)	0.7 (6.2)	—	0.9 (8.0)	0.9 (8.0)	0.9 (8.0)
		SB – 25 mm lead	M ₀	0.9 (8.0)	—	1.2 (10.6)	1.2 (10.6)	1.2 (10.6)
		ST – 6 mm lead	M ₀	—	0.7 (6.2)	1.9 (16.8)	1.9 (16.8)	1.9 (16.8)
Weight	SB	@ 0 Stroke	m ₀	4.0 (8.80)	—	5.2 (11.44)	5.9 (12.98)	5.2 (11.44)
		Per Meter of Stroke	m _{OS}	9.4 (20.68)	—	13.6 (29.92)	16.0 (35.20)	13.2 (29.04)
		Carriage ⁴	m _C kg (lbs)	1.2 (2.64)	—	3.5 (7.70)	6.1 (13.42)	3.7 (8.14)
	ST	@ 0 Stroke	m ₀	—	3.8 (8.36)	5.0 (11.00)	5.7 (12.54)	5.0 (11.00)
		Per Meter of Stroke	m _{OS}	—	10.6 (23.32)	14.8 (32.56)	17.2 (37.84)	14.4 (31.68)
		Carriage ⁴	m _C	—	1.3 (2.86)	3.6 (7.92)	6.2 (13.64)	3.8 (8.36)

¹ PowerSlide or ProLine bearings can be ordered individually with assigned part number in the table and specified, five digit order stroke value (mm), following the part number (-nnnnn) to designate the appropriate length guide rail. To order PowerSlide or Proline bearing with the actuator, use the appropriate order code in item ⑩ of Ordering Information.

² Longer strokes available upon request. Contact factory.

³ Load and moment based on 8000 km performance Refer to “Calculating Load Factors” for additional information.

⁴ For tandem option (OSPE..SB), double the values listed.

OSPE..SB/ST Life Performance

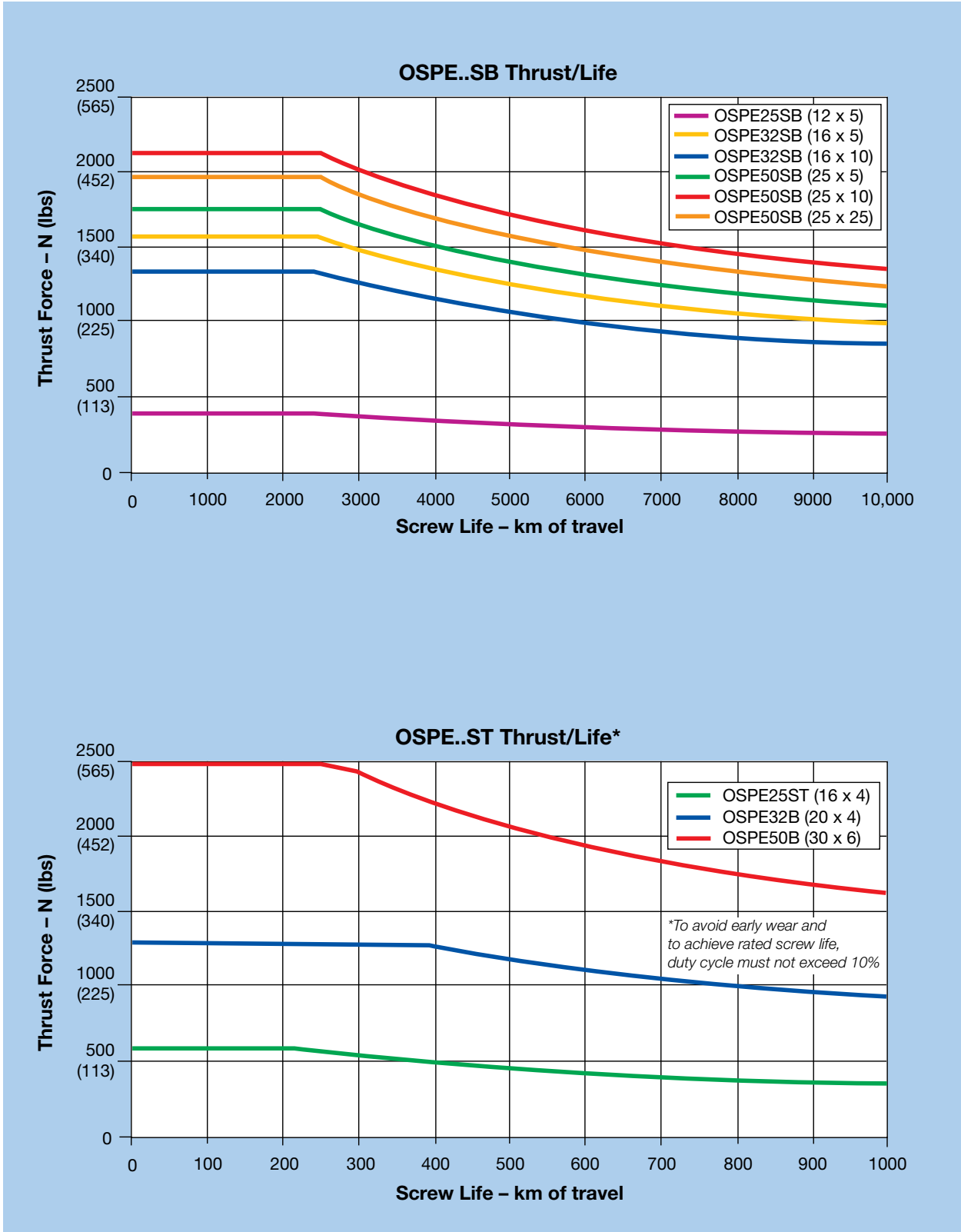

Speed Performance

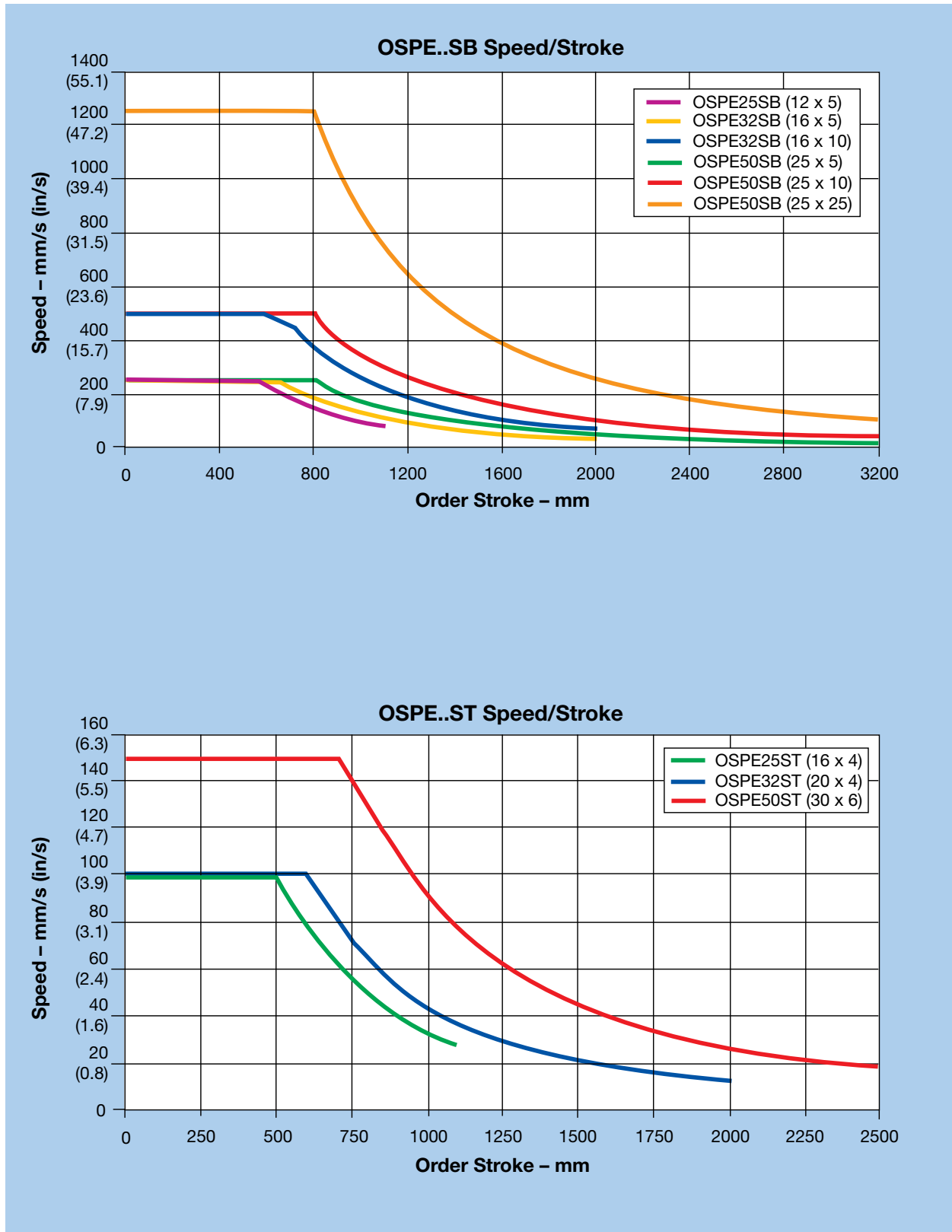

Maximum Permissible Unsupported Length — Determining end cap and profile mounting placement

OSPE..SB/ST Series actuators need to be mounted onto a solid machine base or frame structure using appropriately positioned end cap and profile mounts. This ensures that the actuator will not undergo excessive deflection based on the application's load and length requirements.

The greater the load and/or the longer the unsupported length between mounts, the more the actuator is susceptible to deflection. Loading is also dependent on the carriage orientation (F_z for top oriented carriage or F_y for a side mounted carriage).

Standard Carriage, Tandem Carriage, PowerSlide or ProLine

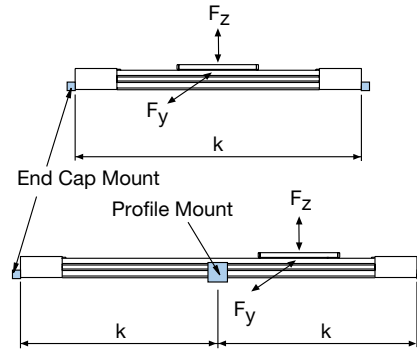

To determine correct end cap and profile mount placement, please follow the steps shown in the example below.

Use the deflection graphs on the next page to ensure that the load will not exceed the maximum allowed deflection.

Example:

A horizontal application uses an OSPE32B with a top oriented carriage. The maximum load to the carriage is 80 kg and the order stroke is 1,550 mm (see previous section to calculate order stroke).

Therefore, the overall length of the actuator will be 1,800 mm:

$$1,550 \text{ mm} + 2 \times \text{Dim "X"} (125 \text{ mm}) = 1,800 \text{ mm}$$

- 1) Use the appropriate F_z graph) for a top loaded carriage. (Note: with the standard carriage, top loaded F_z and side loaded F_y values are the same).
- 2) Calculate the Load "F" in Newtons based on the 80 kg application load requirement:

$$80 \text{ kg} \times 9.81 \text{ kg/ms}^2 = 784.8 \text{ N}$$

- 3) Draw a line from 785 N on the Y-axis to the OSPE32B curve, then down to the X-axis.
- 4) The value of "k" is approximately 1,600 mm.
- 5) Since the overall length (1,800 mm) is greater than this value "k", the actuator will require an additional third fixture point — one end cap mount and two profile mounts — equally spaced to create a distance "k" of 800 mm in between.
- 6) Maximum deflection of the actuator with this mounting configuration will be less than 1.6 mm:

$$0.2\% \text{ of } 800 \text{ mm} = 1.6 \text{ mm}$$

Standard Carriage Load-Distance

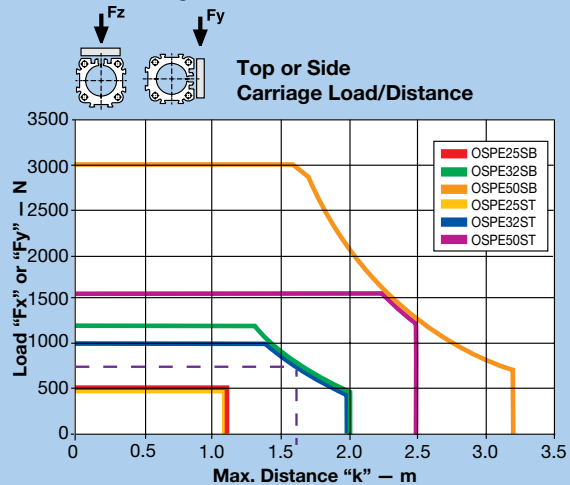

To further reduce deflection:

If the application requires less deflection, then simply reduce the distance "k" appropriately. In this example, for instance, the application must not exceed 1 mm (1/2 the maximum deflection calculated). Therefore, "k" must also be 1/2, or 400 mm.

To achieve this reduced maximum deflection, the actuator will require five fixture points — one end cap mount and four profile mounts — equally spaced with a distance "k" of 400 mm in between.

Standard Carriage Load-Distance

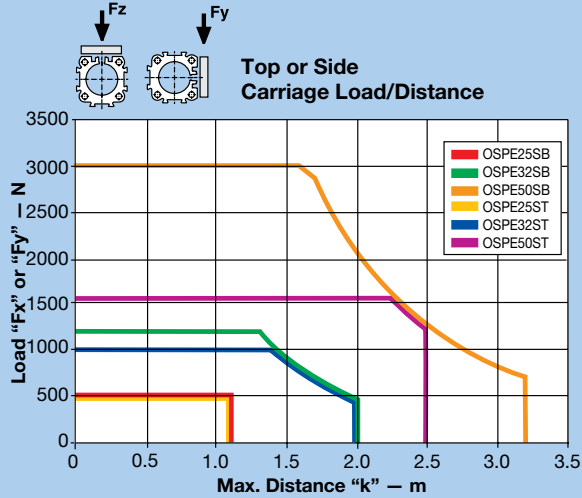

Maximum Permissible Unsupported Length

Determining end cap and profile mounting placement

Use the appropriate deflection graph to ensure that the application load does not exceed the deflection curve. Supporting the actuator within the recommended maximum distance "k" will ensure that the installation will have a maximum deflection equal to 0.2% of distance "k."

To further reduce deflection, simply reduce the distance between end cap and profile mounts as described in the example on the previous page.

PowerSlide Carriage Load-Distance

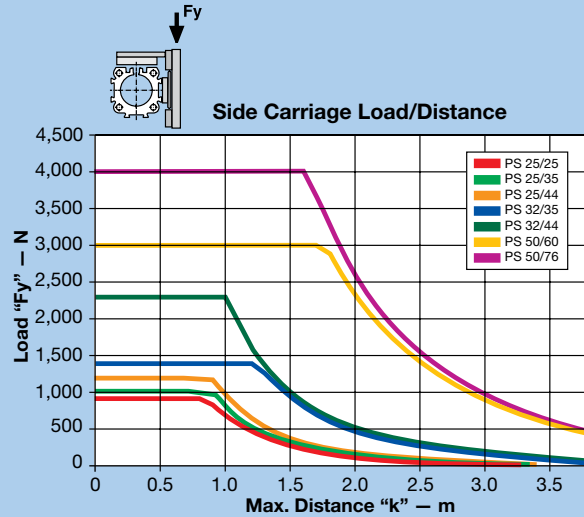
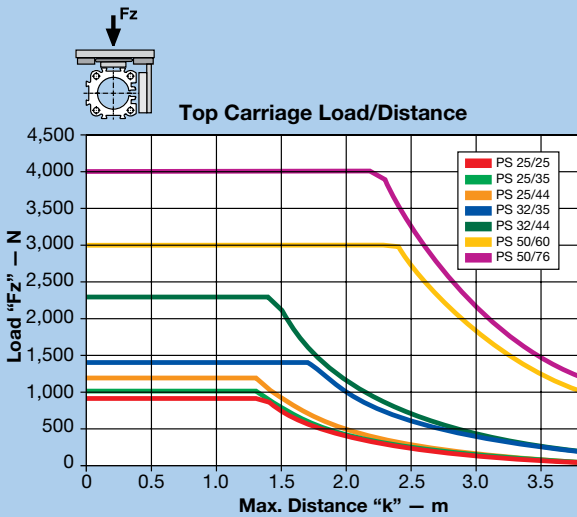

ProLine Carriage Load-Distance

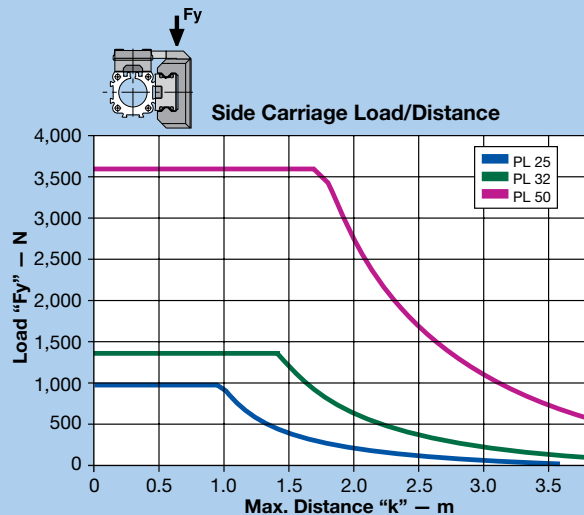
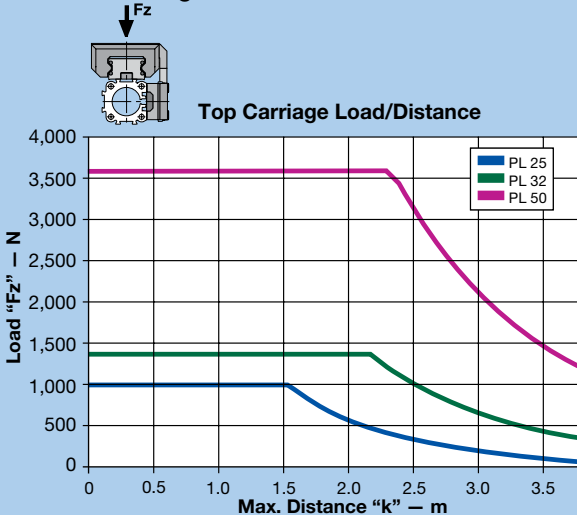

Base Unit Dimensions w/Standard Carriage — mm

Download 2D & 3D files from parker.com/emc

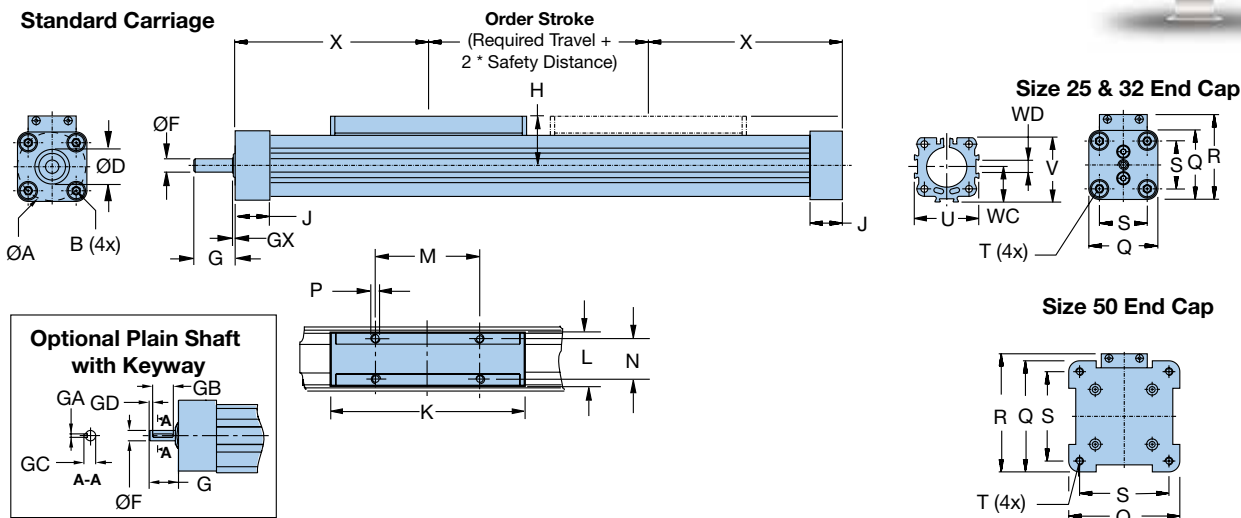

Tandem Carriage (SB models only)

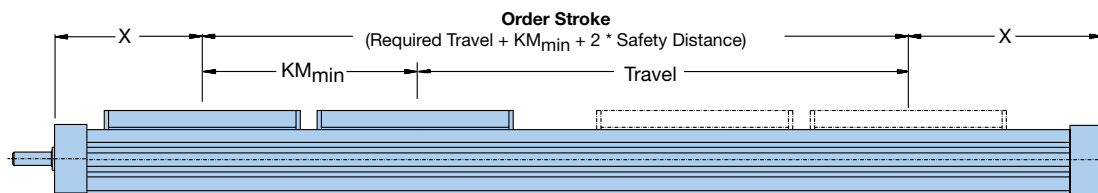

Actuator Size	A	B	D	F	G*	GA	GB	GC	GD	GX	H	J	K
OSPE25SB/ST	38.2	M5 x 10	19 ^{H7}	6 _{h7}	17	2 ^{P9}	12	6.8	2	2	31	22.0	117
OSPE32SB/ST	50.9	M6 x 12	26 ^{H7}	10 _{h7}	31	3 ^{P9}	16	11.2	5	2	38	25.5	152
OSPE50SB/ST	65.0	M6 x 12	40 ^{H7}	15 _{h7}	43	5 ^{P9}	28	17.0	6	3	49	33.0	200

	L	M	N	P	Q	R	S	T	U	V	WC	WD	X
OSPE25SB/ST	33	65	25	M5 x 8	41	52.5	27	M5 x 10	40	39.5	21.5	10.4	100
OSPE32SB/ST	36	90	27	M6 x 10	52	66.5	36	M6 x 12	52	51.7	28.5	10.4	125
OSPE50SB/ST	36	110	27	M6 x 10	87	92.5	70	M6 x 12	76	77.0	43.0	10.4	175

* With optional long drive shaft with keyway, dimension "G" is 24 mm for OSPE25SB/ST; 41 mm for OSPE32SB/ST; 58 mm for OSPE50SB/ST (See Ordering Information, order code ⑦, option "4 —")

Order Stroke Dimensional Requirements

Actuator Size	KM _{min}	KM _{rec}
OSPE25SB/ST	120	190
OSPE32SB/ST	165	230
OSPE50SB/ST	235	320

KM_{min} is the minimum distance between two carriages possible; KM_{rec} is the recommended distance for optimal performance.

* Order Stroke Safety Distance:

The mechanical end position should not be used as a mechanical end stop, thus an additional **Safety Distance** at both ends of travel must be incorporated into the Order Stroke. The safety distance for servo-driven systems is equivalent to the travel distance per revolution of the drive shaft. AC motor-driven systems with VFD require a larger safety distance than servo systems. For further information and design assistance, please consult factory.



PowerSlide Dimensions — mm

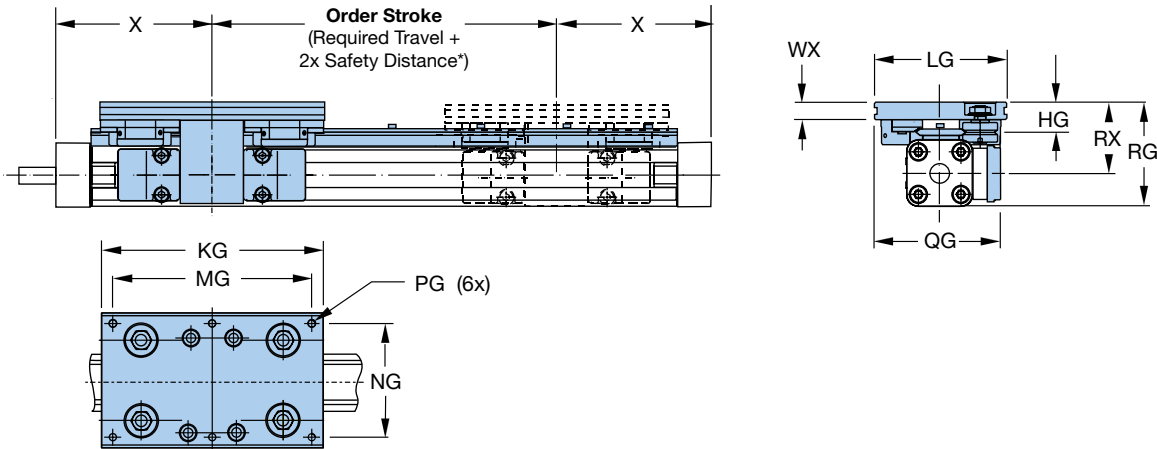

Guide Rail Size	HG	KG	LG	MG	NG	PG	QG	RG	RX	WX	X
PS25/25	20.0	145	80	125	64	M6 x 11	79.5	73.5	53.0	11.0	100
PS 25/35	21.5	156	95	140	80	M6 x 12	89.5	73.0	52.5	12.5	100
PS25/44	26.0	190	116	164	96	M8 x 15	100.0	78.5	58.0	15.0	100
PS32/35	21.5	156	95	140	80	M6 x 12	95.5	84.5	58.5	12.5	125
PS 32/44	26.0	190	116	164	96	M8 x 15	107.0	90.0	64.0	15.0	125
PS50/60	28.5	240	135	216	115	M8 x 17	130.5	123.5	81.0	17.0	175
PS 50/76	39.0	280	185	250	160	M10 x 20	155.5	135.5	93.0	20.0	175

ProLine Dimensions — mm

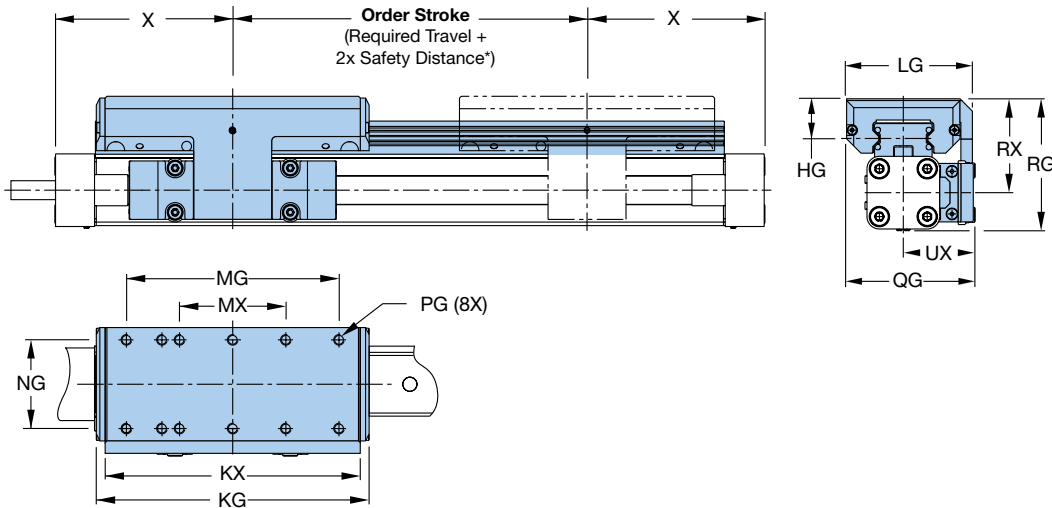

Guide Rail Size	HG	KG	KX	LG	MG	MX	NG	PG	QG	RG	RX	UX	X
PL 25	23	154	144	64	120	60	50	M6 x 12	72.5	74	53	40.5	100
PL 32	25	197	187	84	160	80	64	M6 x 12	91.0	88	62	49.0	125
PL 50	31.6	276	266	110	240	120	90	M6 x 16	117.0	118	75	62.0	175

Order Code

R Clevis Mounting Option for Standard Carriage

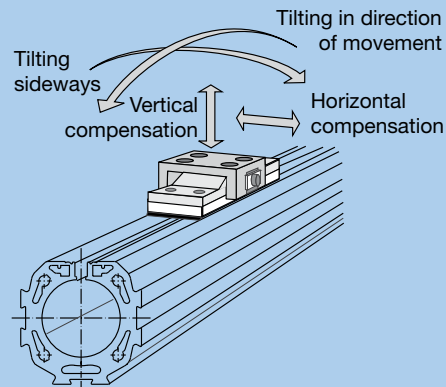

The aluminum clevis mount option bolts directly to the standard carriage to eliminate parallelism deviations and strain to the carriage when the actuator is mounted onto machine guide rails. Clevis mounting provides compensation for misalignment in Z and Y directions and can tilt around the X and Y axis.

When external guides are involved in the application, slight parallelism deviations can lead to mechanical strain on the carriage and actuator. This can be avoided by the use of a clevis mount that provides freedom of movement compensation on several axes.

OSPE25 and OSPE32

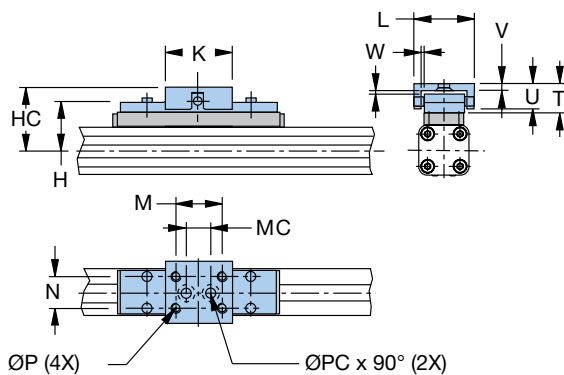

OSPE50

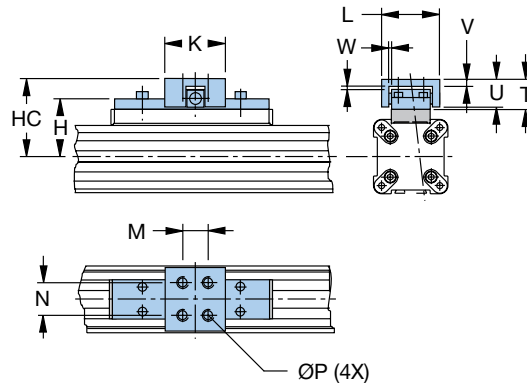

Dimensions — mm

Actuator Size	Part Number	Weight* (kg)	H	HC	K	L	M	MC	N	P	PC	T	U	V	W
OSPE25SB/ST	20005FIL	0.091	39	52	40	38	30	16	16	M5	5.5	21	19	3.5	2
OSPE32SB/ST	20096FIL	0.091	50	68	60	62	46	40	25	M6	6.6	30	28	6.0	2
OSPE50SB/ST	20097FIL	0.308	61	79	60	62	46	—	25	M6	—	30	28	6.0	2

*Part number and weight are for individual unit.

Order
Code

M Inversion Mounting Option for Standard Carriage



For dirty environments or space-restricted installations, inversion of the actuator is recommended.

The aluminum inversion bracket transfers the driving force to the opposite side of the actuator

allowing the load to be attached to the top side of the actuator while the carriage and sealing band remain protected on the bottom side. The size and position of the mounting holes are the same as on the standard carriage.

Note: Profile mounts and magnetic switches can only be used on the free side of the actuator.

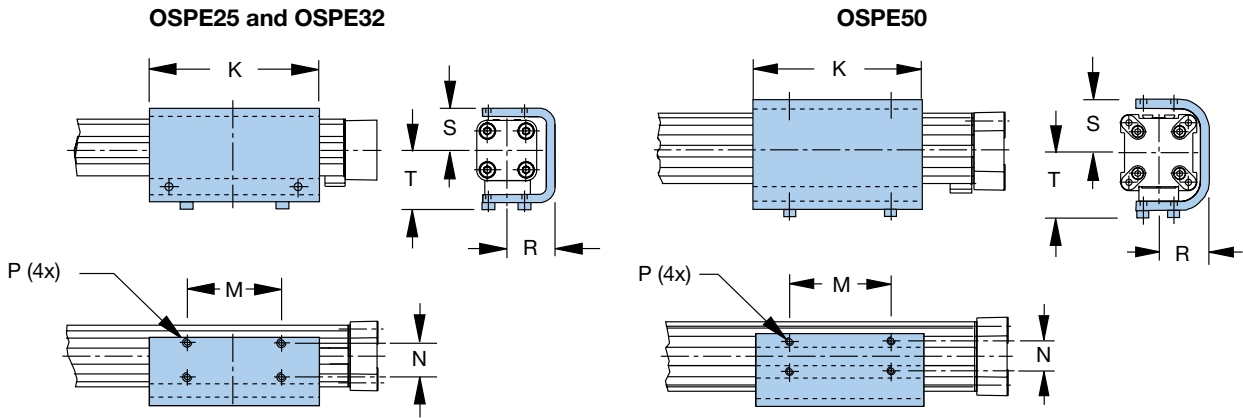

Actuator Size	Part Number	Weight* (kg)	Dimensions – mm						
			K	M	N	P	R	S	T
OSPE25SB/ST	20037FIL	0.302	117	65	25	M5 x 6	33.5	31	43
OSPE32SB/ST	20161FIL	0.449	150	90	27	M6 x 6	39.5	38	51
OSPE50SB/ST	20166FIL	0.947	200	110	27	M6 x 8	52.0	55	65

*Part number and weight are for individual unit.

Motor Mounting Kit Options



Motor Mounting Kits include a coupling housing, coupling and flange

Note: Screw thread to mount motor to flange plate is M3

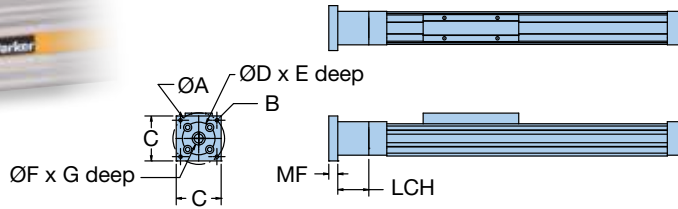

- A = Bolt circle diameter
- B = Screw for bolt circle
- C = Square dimension
- D = Pilot diameter
- E = Pilot depth
- F = Input drive shaft diameter
- G = Input drive shaft length
- LCH = Length coupling housing
- MF = Motor flange

Actuator Size	Order Code ⑥*	Order Code ⑦*	Dimensions – mm								
			A	B	C	D	E	F	G	LCH	MF
OSPE25SB/ST	0	AA **	46.66	M3	56	20.00	1.6	6.35	24.8	38	10
	0	AB	66.67	M4	58	38.10	1.6	6.35	20.5	38	9
	0	AC	66.67	M5	58	38.10	1.6	9.53	20.8	38	9
	0	AD	66.67	M5	60	38.10	1.6	9.53	31.8	38	17
	0	B5 **	46.00	M4	56	30.00	2.5	6.00	25.0	38	10
	0	AM **	46.00	M3	56	30.00	2.5	8.00	25.0	38	10
	0	B6	63.00	M4	60	40.00	2.5	9.00	20.0	38	9
	0	AH	63.00	M5	60	40.00	2.5	9.00	20.0	38	10
	0	A2	63.00	M5	60	40.00	2.5	11.00	23.0	38	10
	0	B7	70.00	M5	60	50.00	3.0	8.00	25.0	38	15
	0	B8	70.00	M5	60	50.00	3.0	12.00	30.0	38	15
	0	AG	75.00	M5	70	60.00	2.5	11.00	23.0	38	10
0	B1	90.00	M5	75	60.00	2.5	11.00	23.0	38	10	
OSPE32SB/ST	0	AB	66.67	M5	60	38.10	1.6	6.35	20.5	54	10
	0	AC	66.67	M5	60	38.10	1.6	9.525	20.8	54	10
	0	AD	66.67	M5	60	38.10	1.6	9.525	31.8	54	17
	0	AE	98.43	M5	85	73.00	3.0	12.70	30.0	54	15
	0	AF	98.43	M6	85	73.00	3.0	12.70	37.0	54	25
	0	B6 **	63.00	M4	74	40.00	2.5	9.00	20.0	54	10
	0	AH **	63.00	M5	74	40.00	2.5	9.00	20.0	54	10
	0	A2 **	63.00	M5	74	40.00	2.5	11.00	23.0	54	10
	0	BJ	66.67	M5	60	38.10	1.6	12.70	20.0	54	10
	0	B7	70.00	M5	60	50.00	3.0	8.00	25.0	54	15
	0	B8	70.00	M5	60	50.00	3.0	12.00	30.0	54	15
	0	AN	70.00	M5	60	50.00	3.0	14.00	30.0	54	15
	0	AG	75.00	M5	70	60.00	2.5	11.00	23.0	54	10
	0	B9	75.00	M5	70	60.00	2.5	14.00	30.0	54	15
	0	BA	75.00	M5	70	60.00	3.0	16.00	40.0	54	25
	0	B0	75.00	M6	70	60.00	3.0	14.00	30.0	54	15
	0	B1	90.00	M5	75	60.00	2.5	11.00	23.0	54	10
	0	B2	90.00	M5	75	60.00	2.5	14.00	30.0	54	15
0	BB	90.00	M6	80	70.00	3.0	14.00	30.0	54	15	
0	B4	90.00	M6	80	70.00	3.0	16.00	40.0	54	25	
0	B3	95.00	M6	80	50.00	2.5	14.00	30.0	54	15	

* When ordering with actuator, use order code ⑥ (gearhead designation) and order code ⑦ to specify motor mounting kit. See Ordering Information.
 ** Motor mounts with 45° rotated

■ Blue order codes indicate rapid shipment availability

(continued on next page)

(continued from previous page)

Actuator Size	Order Code ⑥*	Order Code ⑦*	Dimensions – mm								
			A	B	C	D	E	F	G	LCH	MF
OSPE50SB/ST	0	AE	98.43	M5	88	73.0	3.0	12.70	30.0	75	14
	0	AF	98.43	M6	88	73.0	3.0	12.70	37.0	84	15
	0	B9	75.00	M5	85	60.0	2.5	14.00	30.0	75	14
	0	BA **	75.00	M5	86	60.0	3.0	16.00	40.0	84	15
	0	B0	75.00	M6	88	60.0	3.0	14.00	30.0	75	14
	0	B2	90.00	M5	80	60.0	2.5	14.00	30.0	75	14
	0	BB	90.00	M6	80	70.0	3.0	14.00	30.0	75	14
	0	B4	90.00	M6	86	70.0	3.0	16.00	40.0	84	15
	0	AP	90.00	M6	86	70.0	3.0	19.00	40.0	84	15
	0	B3	95.00	M6	85	50.0	2.5	14.00	30.0	75	14
	0	A1	99.00	M6	88	73.0	3.0	9.525	31.5	75	14
	0	A3	100.00	M6	88	80.0	3.5	14.00	30.0	75	14
	0	AL	100.00	M6	88	80.0	3.0	16.00	40.0	84	15
	0	AJ	100.00	M6	88	80.0	3.0	19.00	40.0	84	15
	0	A4	115.00	M8	100	95.0	3.5	19.00	40.0	84	15
	0	BD	130.00	M8	115	95.0	3.0	19.00	40.0	84	15
	0	BF	130.00	M8	115	110.0	3.5	19.00	40.0	84	15

* When ordering with actuator, use order code ⑥ (gearhead designation) and order code ⑦ to specify motor mounting kit. See Ordering Information.

** Motor mounts with 45° rotated

■ Blue order codes indicate rapid shipment availability

Mounted Motor Options

Mounted Motor Options include a coupling housing, coupling, flange and motor

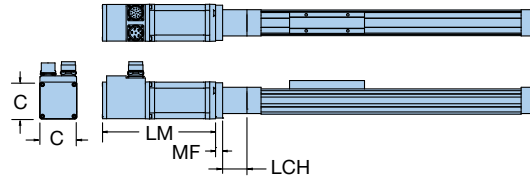

C = Square dimension
 LCH = Length coupling housing
 LM = Length motor
 MF = Motor flange

Actuator Size	Order Code ⑥*	Order Code ⑦*	Motor description	Dimensions – mm			
				C	LCH	LM	MF
OSPE25SB/ST	0	L0	LV233-01-10	58	38	79	9
	0	L1	HV233-01-10	58	38	79	9
	0	K0	BE233FJ-KPSN	58	38	143	17
	0	K1	BE233FJ-KPSN with brake (CM233FJ-115027)	58	38	178	17
	0	KA	PM-FAL01AM8N	40	38	95.2	10
	0	KB	PM-FAL01AM8N2 (Brake)	40	38	131.6	10
OSPE32SB/ST	0	L0	LV233-01-10	58	54	79	10
	0	L1	HV233-01-10	58	54	79	10
	0	L2	LV343-01-10	86	54	127	25
	0	L3	HV343-01-10	86	54	127	25
	0	K0	BE233FJ-KPSN	58	54	143	18
	0	K1	BE233FJ-KPSN with brake (CM233FJ-115027)	58	54	178	18
	0	K2	BE344LJ-KPSN	86	54	188	16
	0	K3	BE344LJ-KPSB	86	54	220	16
	0	KC	PM-FBL04AMK	62	54	108.2	15
OSPE50SB/ST	0	KD	PM-FBL04AMK2	62	54	148.2	15
	0	L2	LV343-01-10	86	84	127	15
	0	L3	HV343-01-10	86	84	127	15
	0	K2	BE344LJ-KPSN	86	75	188	14
	0	K3	BE344LJ-KPSB	86	75	220	14
	0	KJ	PM-FCL10AMK	80	84	152.7	15
	0	KK	PM-FCL10AMK2 (Brake)	80	84	193	15
	0	M0	MPP0923D1E-KPSN	89	84	178	15
	0	M1	MPP0923D1E-KPSB	89	84	212	15
	0	M2	MPP1003D1E-KPSN	98	84	175	15
	0	M3	MPP1003D1E-KPSB	98	84	224	15
	0	M4	MPP1003R1E-KPSN	98	84	175	15
0	M5	MPP1003R1E-KPSB	98	84	224	15	

*When ordering with actuator, use order code ⑥ (gearhead designation) and order code ⑦ to specify mounted motor. See Ordering Information.

Gearhead Mounting Kit Options

Gearhead Mounting Kits include a coupling housing, coupling and flange

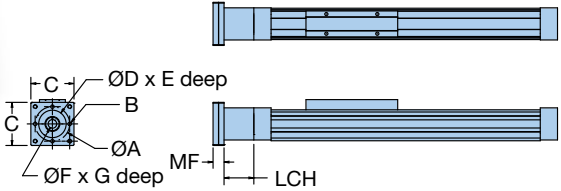

- A = Bolt circle diameter
- B = Screw for bolt circle
- C = Square dimension
- D = Pilot diameter
- E = Pilot depth
- F = Input drive shaft diameter
- G = Input drive shaft length
- LCH = Length coupling housing
- MF = Motor flange

Actuator Size	Order Code ⑥*	Order Code ⑦*	Dimensions — mm								
			A	B	C	D	E	F	G	LCH	MF
OSPE25SB/ST	0	C0	44	S4	54	35	3	12	25	38	14.0
OSPE32SB/ST	0	C0	44	S4	60	35	3	12	25	54	13.0
	0	C1	62	S5	75	52	8	16	36	54	20.0
OSPE50SB/ST	0	C1	62	S5	75	52	8	16	36	84	16.3
	0	C2	80	S6	95	68	10	22	46	84	23.0

*When ordering with actuator, use order code ⑥ (gearhead designation) and order code ⑦ to specify gearhead mounting kit See Ordering Information.

■ Blue order codes indicate rapid shipment availability

Mounted Gearhead with Motor Mounting Kit Options



Mounted Gearhead with Motor Mounting Kit include a coupling housing, coupling, flange, and gearhead with coupler and flange

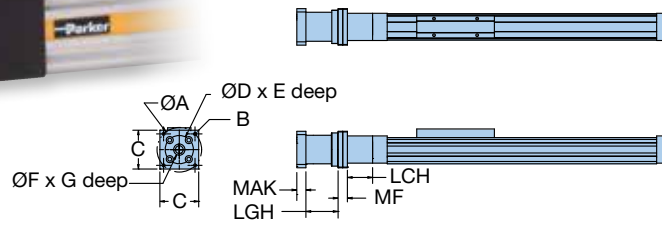

- A = Bolt circle diameter
- B = Screw for bolt circle
- C = Square dimension
- D = Pilot diameter
- E = Pilot depth
- F = Input drive shaft diameter
- G = Input drive shaft length
- LCH = Length coupling housing
- LGH = Length gearhead
- MAK = Motor adapter
- MF = Motor flange

Actuator Size	Order Code ⑥ ¹	Order Code ⑦ ²	Dimensions – mm										
			A	B	C	D	E	F	G	LCH	LGH	MAK	MF
OSPE25SB/ST	A or B	AA	46.66	M3	43	20.00	1.6	6.35	24.8	38	48.5	19.0	14.0
	A or B	AB	66.67	M5	55	38.10	1.6	6.35	20.5	38	48.5	15.7	14.0
	A or B	B5	46.00	M4	43	30.00	2.5	6.00	25.0	38	48.5	19.0	14.0
	A or B	AM	46.00	M3	43	30.00	2.5	8.00	25.0	38	48.5	19.0	14.0
	A or B	B6	63.00	M4	55	40.00	2.5	9.00	20.0	38	48.5	13.7	14.0
	A or B	AH	63.00	M5	55	40.00	2.5	9.00	20.0	38	48.5	19.0	14.0
OSPE32SB/ST	C, D or E	AB	66.67	M5	62	38.10	1.6	6.35	20.5	54	67.0	16.5	20.0
	C, D or E	AC	66.67	M5	62	38.00	1.6	9.525	20.8	54	67.0	16.5	20.0
	C, D or E	AD	66.67	M5	62	38.10	1.6	9.525	31.8	54	67.0	22.5	20.0
	C, D or E	AE	98.43	M5	80	73.03	3.0	12.70	30.0	54	67.0	22.5	20.0
	C, D or E	AF	98.43	M6	85	73.03	3.0	12.70	37.0	54	67.0	30.0	20.0
	C, D or E	B6	63.00	M4	62	40.00	2.5	9.00	20.0	54	67.0	16.5	20.0
	C, D or E	AH	63.00	M5	62	40.00	2.5	9.00	20.0	54	67.0	16.5	20.0
	C, D or E	B8	70.00	M5	62	50.00	3.0	12.00	30.0	54	67.0	22.5	20.0
	C, D or E	AN	70.00	M5	62	50.00	3.0	14.00	30.0	54	67.0	22.5	20.0
	C, D or E	AG	75.00	M5	62	60.00	2.5	11.00	23.0	54	67.0	16.5	20.0
	C, D or E	B9	75.00	M5	62	60.00	2.5	14.00	30.0	54	67.0	22.5	20.0
	C, D or E	BB	90.00	M6	80	70.00	3.0	14.00	30.0	54	67.0	22.5	20.0
	C, D or E	A3	100.00	M6	89	80.00	3.5	14.00	30.0	54	67.0	22.5	20.0
	OSPE50SB/ST	C, D or E	AB	66.67	M5	62	38.10	1.6	6.35	20.5	84	67.0	16.5
C, D or E		AC	66.67	M5	62	38.00	1.6	9.525	20.8	84	67.0	16.5	16.3
C, D or E		AD	66.67	M5	62	38.10	1.6	9.525	31.8	84	67.0	22.5	16.3
C, D or E		AE	98.43	M5	80	73.03	3.0	12.70	30.0	84	67.0	22.5	16.3
C, D or E		AF	98.43	M6	85	73.03	3.0	12.70	37.0	84	67.0	30.0	16.3
C, D or E		B6	63.00	M4	62	40.00	2.5	9.00	20.0	84	67.0	16.5	16.3
C, D or E		AH	63.00	M5	62	40.00	2.5	9.00	20.0	84	67.0	16.5	16.3
C, D or E		B8	70.00	M5	62	50.00	3.0	12.00	30.0	84	67.0	22.5	16.3
C, D or E		AN	70.00	M5	62	50.00	3.0	14.00	30.0	84	67.0	22.5	16.3
C, D or E		AG	75.00	M5	62	60.00	2.5	11.00	23.0	84	67.0	16.5	16.3
C, D or E		B9	75.00	M5	62	60.00	2.5	14.00	30.0	84	67.0	22.5	16.3
C, D or E		BB	90.00	M6	80	70.00	3.0	14.00	30.0	84	67.0	22.5	16.3
C, D or E		A3	100.00	M6	89	80.00	3.5	14.00	30.0	84	67.0	22.5	16.3

¹ When ordering with actuator, use order code ⑥ to specify mounted gearhead size and ratio: **A** PV40TA-005 (ratio 5:1); **B** PV40TA-010 (ratio 10:1); **C** PV60TA-003 (ratio 3:1); **D** PV60TA-005 (ratio 5:1); **E** PV60TA-010 (ratio 10:1). See ordering information.

² When ordering with actuator, use order code ⑦ to specify motor mounting kit. See Ordering Information.

■ Blue order codes indicate rapid shipment availability

Mounted Gearhead and Motor Options

Mounted Gearhead and Mounted Motor Options include a coupling housing, coupling, flange, gearhead with coupler, flange and motor

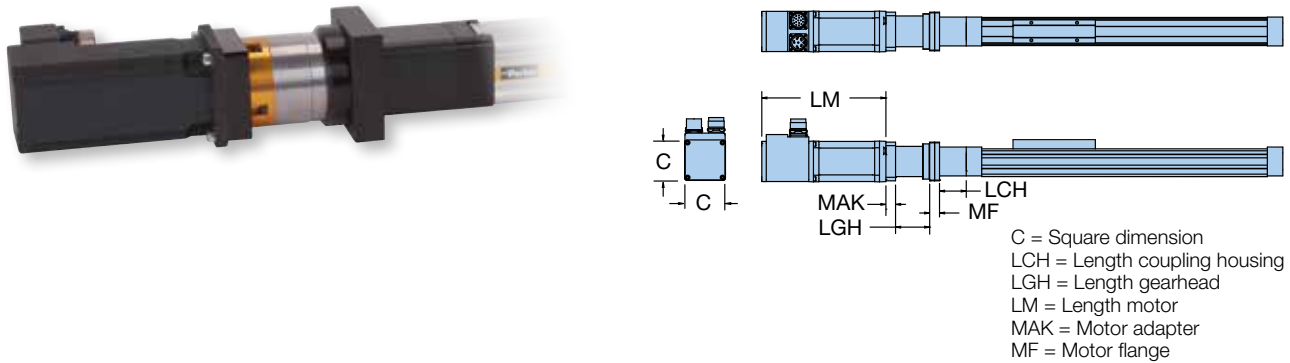

Actuator Size	Order Code ⑥ ¹	Order Code ⑦ ²	Motor description	Dimensions – mm					
				C	LCH	LGH	LM	MAK	MF
OSPE25SB/ST	A or B	KA	PM-FAL01AM8N	40	38	48.5	95.2	19.0	14.0
	A or B	KB	PM-FAL01AM8N2 (Brake)	40	38	48.5	131.6	19.0	14.0
	A or B	L0	LV233-01-10	58	38	48.5	79	15.7	14.0
	A or B	L1	HV233-01-10	58	38	48.5	79	15.7	14.0
OSPE32SB/ST	C, D or E	K0	BE233FJ-KPSN	58	54	67.0	143	22.5	20.0
	C, D or E	K1	BE233FJ-KPSN with brake (CM233FJ-115027)	58	54	67.0	178	22.5	20.0
	C, D or E	K2	BE344LJ-KPSN	86	54	67.0	188	22.5	20.0
	C, D or E	K3	BE344LJ-KPSB	86	54	67.0	220	22.5	20.0
	C, D or E	KC	PM-FBL04AMK	62	54	67.0	108.2	22.5	20.0
	C, D or E	KD	PM-FBL04AMK2	62	54	67.0	148.2	22.5	20.0
	C, D or E	L0	LV233-01-10	58	54	67.0	79	16.5	20.0
	C, D or E	L1	HV233-01-10	58	54	67.0	79	16.5	20.0
	C, D or E	L2	LV343-01-10	86	54	67.0	127	30.0	20.0
	C, D or E	L3	HV343-01-10	86	54	67.0	127	30.0	20.0
OSPE50SB/ST	C, D or E	K0	BE233FJ-KPSN	58	84	67.0	143	22.5	16.3
	C, D or E	K1	BE233FJ-KPSN with brake (CM233FJ-115027)	58	84	67.0	178	22.5	16.3
	C, D or E	K2	BE344LJ-KPSN	86	84	67.0	188	22.5	16.3
	C, D or E	K3	BE344LJ-KPSB	86	84	67.0	220	22.5	16.3
	C, D or E	KC	PM-FBL04AMK	62	84	67	108.2	22.5	16.3
	C, D or E	KD	PM-FBL04AMK2	62	84	67.0	148.2	22.5	16.3
	C, D or E	L0	LV233-01-10	58	84	67.0	79	16.5	16.3
	C, D or E	L1	HV233-01-10	58	84	67.0	79	16.5	16.3
	C, D or E	L2	LV343-01-10	86	84	67.0	127	30.0	16.3
	C, D or E	L3	HV343-01-10	86	84	67.0	127	30.0	16.3



¹ When ordering with actuator, use order code ⑥ to specify mounted gearhead size and ratio: **A** PV40TA-005 (ratio 5:1); **B** PV40TA-010 (ratio 10:1); **C** PV60TA-003 (ratio 3:1); **D** PV60TA-005 (ratio 5:1); **E** PV60TA-010 (ratio 10:1). See Ordering Information.

² When ordering with actuator, use order code ⑦ to specify mounted motor on gearhead. See Ordering Information.

End Cap Mounting Options

See "Maximum Permissible Unsupported Length" for end cap and profile mounting placement requirements.

End Cap Mounting Selection Overview

		Standard Carriage			PowerSlide						ProLine			
Type		25	32	50	25/25	25/35	25/44	32/35	32/44	50/60	50/76	25	32	50
 Standard	A1	•	•											
	A2											•	•	
	A3				•	•		•						
 Reinforced	B1	•	•		•	•	•	•	•			•	•	
	B4							•	•					
 Block	C1			•						•	•			•
	C2													•
	C3									•				
	C4										•			

• Recommended for mounting position with carriage on top • Recommended for mounting position carriage side only (3 or 9 o'clock position)

Order Code

1, 2 or 3
(1 pair)

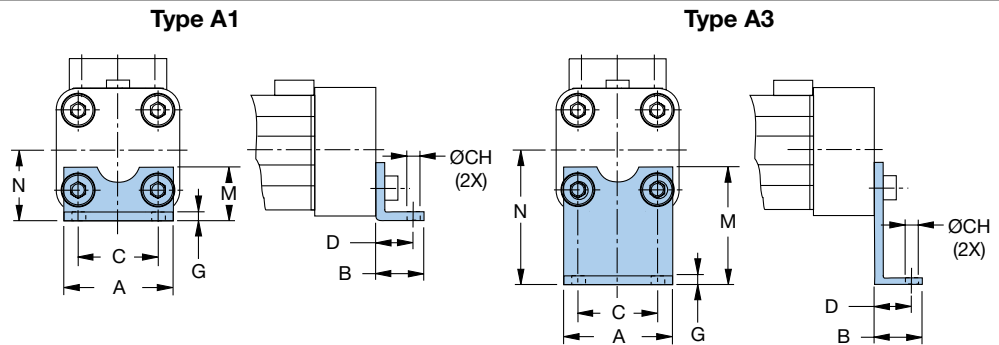

Type A1, A2 and A3 – Standard End Cap

Actuator Size	Type	Part Number*	Weight* (kg)	Dimensions – mm								
				A	B	C	CH	D	G	M	N	
OSPE25SB/ST	A1	18156FIL	0.031								18	22
	A2	18157FIL	0.044	39	22	27	5.8	16	2.5		33	37
	A3	18158FIL	0.055								45	49
OSPE32SB/ST	A1	18161FIL	0.050								20	30
	A2	18162FIL	0.066	50	26	36	6.6	18	3.0		34	44
	A3	18163FIL	0.159								42	52

*Part number and weight are for individual unit.

Order Code

4 or 5
(1 pair)

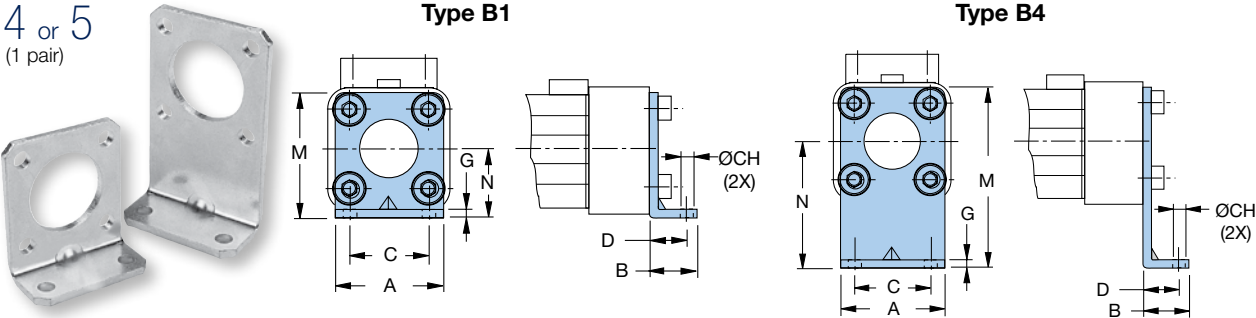

Type B1 and B4 – Reinforced End Cap

Actuator Size	Type	Part Number*	Weight* (kg)	Dimensions – mm							
				A	B	C	CH	D	G	M	N
OSPE25SB/ST	B1	18159FIL	0.010	39	22	27	5.8	16	2.5	42	22
	B4	18160FIL	0.110							80	60
OSPE32SB/ST	B1	18164FIL	0.078	50	26	36	6.6	18	3.0	55	30
	B4	18165FIL	0.380							85	60

*Part number and weight are for individual unit.

Order Code

1, 2, 3 or 4
(1 pair)

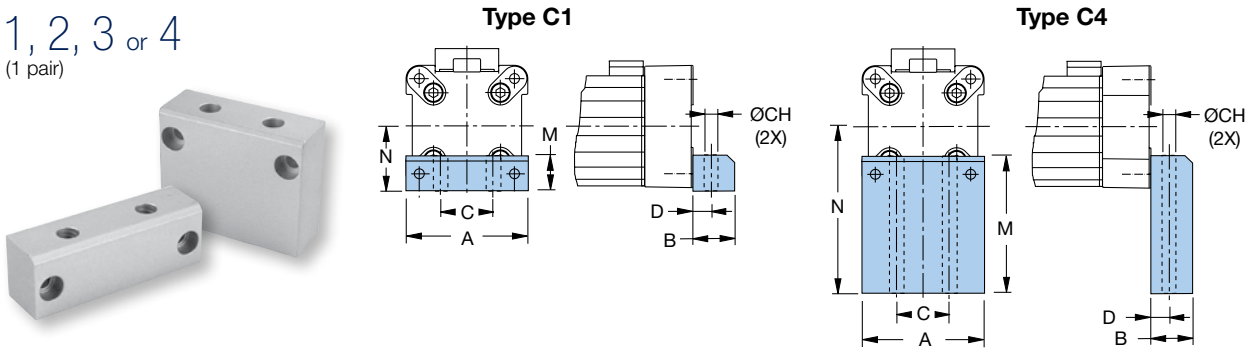

Type C1, C2, C3 and C4 – Block End Cap



Actuator Size	Type	Part Number*	Weight* (kg)	Dimensions – mm						
				A	B	C	CH	D	M	N
OSPE50SB/ST	C1	18166FIL	0.146	86	24	40	9.0	12.5	30	48
	C2	18167FIL	0.210						39	57
	C3	18168FIL	0.300						54	72
	C4	18169FIL	0.412						77	95

*Part number and weight are for individual unit.

Profile Mounting Options

See “Maximum Permissible Unsupported Length” for end cap and profile mounting placement requirements.

Profile Mounting Selection Overview

		Standard Carriage			PowerSlide						ProLine				
Type		25	32	50	25/25	25/35	25/44	32/35	32/44	50/60	50/76	25	32	50	
 2 Internal Threads D1		•	•	•	•	•	•	•	•	•	•	•	•	•	
		•	•	•	•	•	•	•	•	•	•	•	•	•	
 2 Thru Holes E1 E2 E3 E4	E1	•	•	•	•	•	•	•	•	•	•	•	•	•	
	E2											•	•	•	
	E3				•	•		•		•					
	E4						•		•		•				
 3 Thru Holes MAE		•	•	•	•	•	•	•	•	•	•	•	•	•	
	MAE	•	•	•	•	•	•	•	•	•	•	•	•	•	

• Recommended for mounting position with carriage on top • Recommended for mounting position carriage side only (3 or 9 o'clock position)

Order Code

2, 5 or 8
(1, 2 or 3 pair)

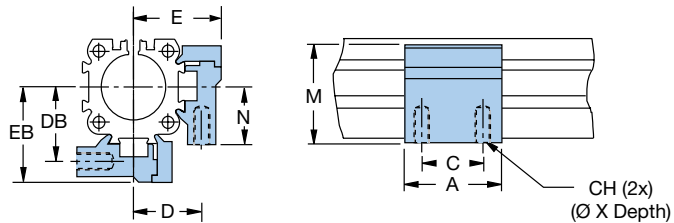

Type D1 (with two internal threads)

			Dimensions — mm								
Actuator Size	Part Number*	Weight* (kg)	A	C	CH	D	DB	E	EB	M	N
OSPE25SB/ST	20008FIL	0.061	50	36	M5 x 10	27	28.5	34.5	36	38	22
OSPE32SB/ST	20157FIL	0.072	50	36	M5 x 10	33	35.5	40.5	43	46	30
OSPE50SB/ST	20162FIL	0.167	60	45	M6 x 11	40	45.0	52.0	57	71	48

*Part number and weight are for individual unit.

Order Code

E1 1, 4 or 7 (1, 2 or 3 pair) E3 L, P or S (1, 2 or 3 pair)
 E2 K, N or R (1, 2 or 3 pair) E4 M, Q or T (1, 2 or 3 pair)

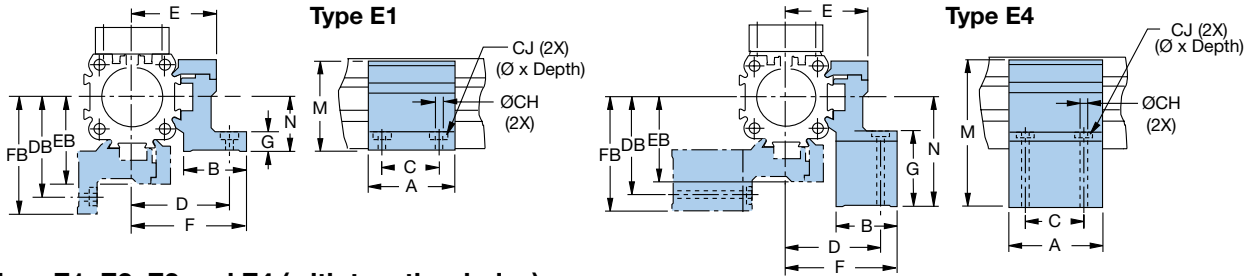
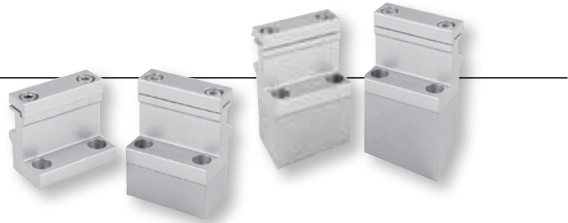

Type E1, E2, E3 and E4 (with two thru holes)

				Dimensions — mm													
Actuator Size	Type	Part Number*	Weight* (kg)	A	B	C	CH	CJ	D	DB	E	EB	F	FB	G	M	N
OSPE25SB/ST	E1	20009FIL	0.074												8	38	22
	E2	20352FIL	0.125	50	26	36	5.5	10 x 5.7	40	41.5	34.5	36	47.5	49	23	53	37
	E3	20353FIL	0.120												35	65	49
	E4	20354FIL	0.020												46	76	60
OSPE32SB/ST	E1	20158FIL	0.092												10	46	30
	E2	20355FIL	0.141	50	27	36	5.5	10 x 5.7	46	48.5	40.5	43	54.5	57	24	60	44
	E3	20356FIL	0.140												32	68	52
	E4	20357FIL	0.197												40	76	60
OSPE50SB/ST	E1	20163FIL	0.189												10	71	48
	E2	20361FIL	0.235	60	34	45	7.0	—	59	64.0	52.0	57	67.0	72	19	80	57
	E3	20362FIL	0.338												31	95	72
	E4	20363FIL	0.442												57	118	95

*Part number and weight are for individual unit.

Order Code

3, 6 or 9 (1, 2 or 3 pair)

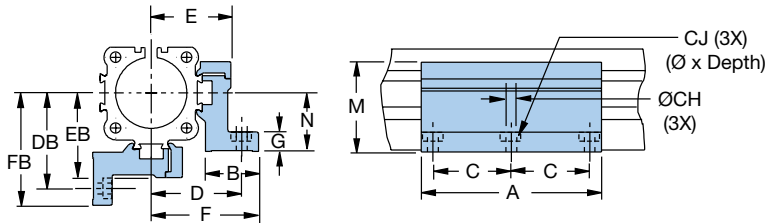
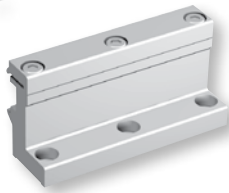

Type MAE (with three thru holes)

				Dimensions — mm													
Actuator Size	Type	Part Number*	Weight* (kg)	A	B	C	CH	CJ	D	DB	E	EB	F	FB	G	M	N
OSPE25SB/ST		12278FIL	0.271	92	26	40	5.5	10 x 5.7	40	41.5	34.5	36	47.5	49	8	38	22
OSPE32SB/ST		12279FIL	0.334	92	27	40	5.5	10 x 5.7	46	48.5	40.5	43	54.5	57	10	46	30
OSPE50SB/ST		12280FIL	0.668	112	34	45	7.0	—	59	64.0	52.0	57	67.0	72	10	71	48

*Part number and weight are for individual unit.

ORDERING INFORMATION

OSPE..SB/ST

Select an order code from each of the numbered fields to create a complete OSPE..SB or ST model order number. Include hyphens and non-selective characters as shown in example below.

① ② ③ ④ ⑤ ⑥ ⑦ ⑧ ⑨ ⑩ ⑪ ⑫ ⑬ ⑭

Order Number Example: OSPE 25 - 1 0 0 0 0 - 00000 - P 0 0 0 0 0

① Series

OSPE Origa System Plus Electromechanical

② Actuator Bore Size

- 25** 41 mm W x 53 mm H
- 32** 52 mm W x 67 mm H
- 50** 87 mm W x 93 mm H

③ Drive Train

- 1** SB – Ball screw actuator with internal glider bearing
- 2** ST – Trapezoidal screw actuator with internal glider bearing

④ Carriage

- 0** Standard
- 1** Tandem (two carriages for higher load capabilities (OSPE..SB models only))

⑤ Screw Lead

OSPE..SB	Bore Size	25	32	50
3 5 mm		•	•	•
4 10 mm			•	•
5 25 mm				•
OSPE..ST	Bore Size	25	32	50
4 4 mm		•	•	
6 6 mm				•

⑥ Mounted Gearhead Options

- 0** No gearhead
- A** PV40TA-005 (gear ratio 5:1)*
- B** PV40TA-010 (gear ratio 10:1)*
- C** PV60TA-003 (gear ratio 3:1)*
- D** PV60TA-005 (gear ratio 5:1)*
- E** PV60TA-010 (gear ratio 10:1)*

* Requires selection from "Mounted Gearhead with Motor Mounting Kit" or "Mounted Gearhead and Motor" (see Options & Accessories) for item ⑦ below.

⑦ Drive Shaft and Gearhead/Motor Mounting Options

- 0 -** Plain drive shaft
 - 3 -** Drive shaft with keyway
 - 4 -** Long drive shaft with keyway
- Motor Mounting Kits* (see Options & Accessories for available option dimensions and delivery)
- Mounted Motors* (see Options & Accessories for available option dimensions and delivery)
- Gearhead Mounting Kits* (see Options & Accessories for available option dimensions and delivery)
- Mounted Gearhead with Motor Mounting Kits* (see Options & Accessories for available option dimensions and delivery)
- Mounted Gearhead and Motor (see Options & Accessories for available option dimensions and delivery)

* All gearhead and motor mounting options are equipped with a plain drive shaft (no keyway options)

⑧ Order Stroke*

00000 5-digit input (in mm)

* See Specifications to calculate required order stroke.

Maximum catalog stroke:

OSPE25SB/ST = 01100 mm;

OSPE32SB/ST = 02000 mm;

OSPE50SB/ST = 02000 mm

Longer strokes available upon request. Consult factory.

⑨ Hardware and Dovetail Groove Covers

- P** Standard hardware with Parker gold cover strip

■ Blue order codes indicate rapid shipment availability

Free sizing and selection support from Virtual Engineer at virtualengineer.com





⑩ Carriage Options

- 0** No external guide rail
- 6** ProLine PL25, PL32, PL50*
- E** PowerSlide PS25/25*
- F** PowerSlide PS25/35 or PS32/35*
- G** PowerSlide PS25/44 or PS32/44*
- H** PowerSlide PS50/60*
- I** PowerSlide PS50/76*
- M** Inversion Mounting**
- R** Clevis Mounting **

* Requires standard carriage (select order code "0" from ④). See Dimensions for additional information.

** Requires standard carriage (select order code "0" from ④). See Options & Accessories for Clevis Mounting and Inversion Mounting.

⑪ External Guide Rail Orientation

- 0**  Guide Rail (right)
- 1**  Guide Rail (left)

⑫ End Cap Mounting (see Options & Accessories)

- 0** No end cap mounting
- 1** 1 piece A1* (standard end cap) or C1** (block end cap)
- 2** 1 piece A2* (standard end cap) or C2** (block end cap)
- 3** 1 piece A3* (standard end cap) or C3** (block end cap)
- 4** 1 piece B1* (reinforced end cap) or C4** (block end cap)
- 5** 1 piece B4* (reinforced end cap)

* For size 25 and 32

** For size 50

⑬ Profile Mounting (see Options & Accessories)

- 0** No profile mounting
- 2** 1 pair D1 (with 2 internal threads)
- 5** 2 pair D1 (with 2 internal threads)
- 8** 3 pair D1 (with 2 internal threads)
- 1** 1 pair E1 (with 2 thru holes)
- 4** 2 pair E1 (with 2 thru holes)
- 7** 3 pair E1 (with 2 thru holes)
- 3** 1 pair MAE (with 3 thru holes)
- 6** 2 pair MAE (with 3 thru holes)
- 9** 3 pair MAE (with 3 thru holes)
- K** 1 pair E2 (with 2 thru holes)
- N** 2 pair E2 (with 2 thru holes)
- R** 3 pair E2 (with 2 thru holes)
- L** 1 pair E3 (with 2 thru holes)
- P** 2 pair E3 (with 2 thru holes)
- S** 3 pair E3 (with 2 thru holes)
- M** 1 pair E4 (with 2 thru holes)
- Q** 2 pair E4 (with 2 thru holes)
- T** 3 pair E4 (with 2 thru holes)

⑭ Magnetic Sensor Mounting*

- 0** No sensor mounting
- A** 1 pc. N.O., NPN, with M8 connector
- B** 2 pc. N.C., NPN, with M8 connector
- C** 1 pc. N.O., NPN, with M8 connector
2 pc. N.C., NPN, with M8 connector
- D** 1 pc. N.O., PNP, with M8 connector
- E** 2 pc. N.C., PNP, with M8 connector
- F** 1 pc. N.O., PNP, with M8 connector
2 pc. N.C., PNP, with M8 connector

* Extension cable with M8 plug and 5 m cable flying lead cable for Sensor with M8 connector can be ordered separately; use part number 003-2918-01

■ Blue order codes indicate rapid shipment availability