

MX80S Ballscrew and Leadscrew Driven Stages

Reliable, low profile miniature positioner

- Cross roller bearing (zero cage creep option)
- Stepper or servo motor drive
- Digital limit/home system
- Optional linear encoder
- Cleanroom prep. option

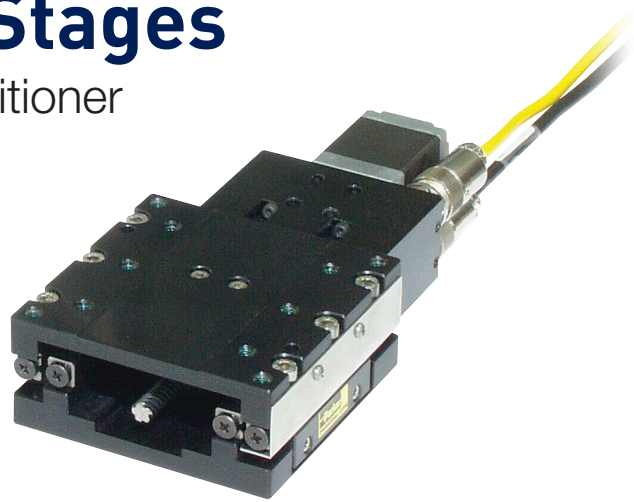

- Miniature Size - Low Profile (35 mm high X 80 mm wide)
- Normal or cleanroom environments
- 25, 50, and 100 mm travels
- Multi-axis platform
- Ballscrew or leadscrew drive options

MX80S Table

Duty Cycle	Max Acceleration	Max Load	Max Travel	Peak Force	Repeatability (+/-)
100%	2 G	8 kG	100 mm	123 N	1.5 µm

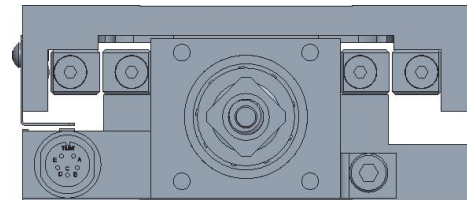

MX80S

The MX80S miniature positioner is the screw driven member of Parker’s MX80 and mSR family. Like its counterparts, the MX80L, mSR80, and mSR100 linear motor-driven stages, and the MX80M manual stage, the MX80S is designed for applications requiring reliable linear positioning in space restricted applications. It is the complementary product that provides easy mounting compatibility where screw driven stage performance is ideal for the application.

The MX80S can be supplied with a high-efficiency leadscrew drive capable of reaching 200 mm per

second velocity, or a precision ground ballscrew drive offering axial thrust to 123 N.

The leadscrew drive employs a PTFE coated leadscrew with a preloaded nut to produce extremely smooth linear translation. A choice of three leads provides improved opportunity for matching desired velocity/resolution requirements.

The 2.0 mm lead ballscrew stage offers high performance 24/7 operation with a thrust load capacity of 123 N (28 lb) and velocity to 100 mm/second at 100% duty cycle.



Leadscrew drive



Ballscrew drive

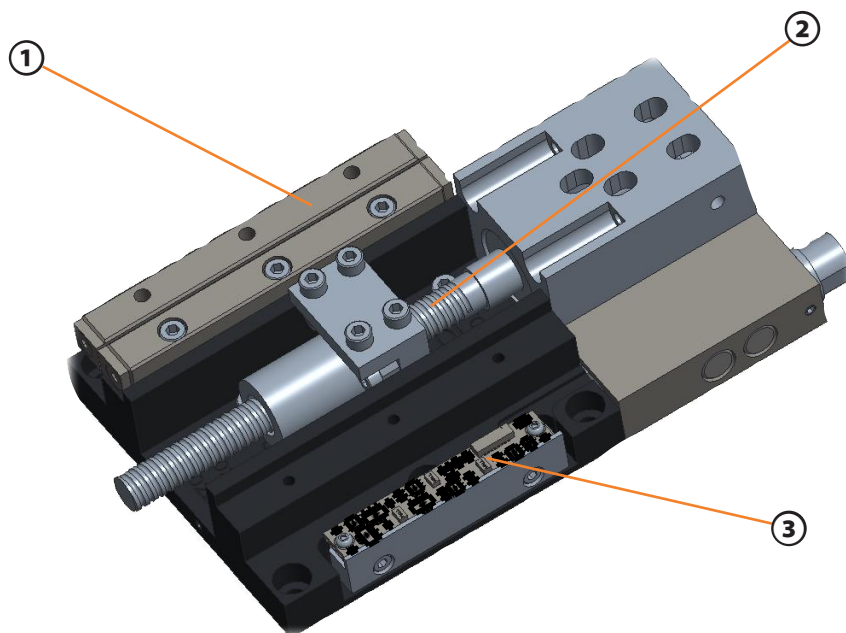

Miniature
Positioners

① Cross Roller Bearings

provide high stiffness and extremely smooth linear translation. A rack and pinion anti-cage creep design within the bearing races prevents cage creep even at 5 g acceleration, or with cantilevered loads.

③ Home/Limit Sensors

are magnetic sensors completely housed within the body of the stage, and fully adjustable over the entire travel range.

② Ballscrew or leadscrew drive

The 2.0 mm lead ballscrew driven stage offers high performance 24/7 operation with a thrust load capacity of 123 N (28 lb.) and velocity to 100 mm/second at 100% duty cycle. Leadscrew driven stages are available with 1 mm, 2 mm, or 10 mm leads. The PTFE coated leadscrew provides extremely smooth linear translation at velocities up to 200 mm/second.

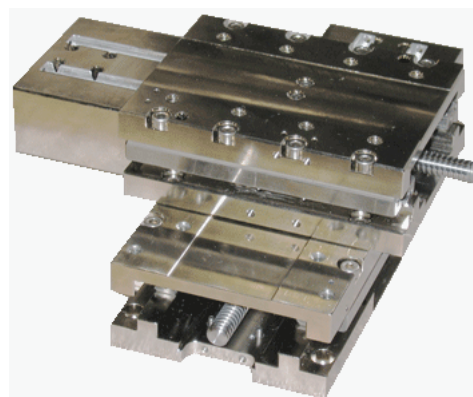

SPECIFICATIONS

The MX80S low profile miniature positioner offers reliable linear positioning for space restricted applications. Various screw and drives options are available to best suit the application's needs.

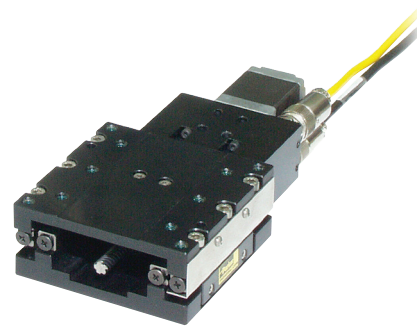

		MX80S Leadscrew Drive			MX80S Ballscrew Drive		
Travel (mm)		25	50	100	25	50	100
Normal Load Capacity	kg (lb)	8 (18)	8 (18)	8 (18)	8 (18)	8 (18)	8 (18)
Thrust Load Capacity	N (lb)	44 (10)	44 (10)	44 (10)	123 (28)	123 (28)	123 (28)
Maximum Velocity							
1.0 mm lead	mm/sec	20	20	20	—	—	—
2.0 mm lead		40	40	40	100	100	100
10.0 mm lead		200	200	200	—	—	—
Breakaway Torque	Nm	0.029	0.029	0.033	0.050	0.050	0.050
Running Torque							
1.0 mm lead	Nm	0.028	0.028	0.032	—	—	—
2.0 mm lead		0.028	0.028	0.032	0.047	0.047	0.047
10.0 mm lead		0.028	0.028	0.032	—	—	—
Duty Cycle	%	50	50	50	100	100	100
Straightness & Flatness*	µm	8	12	16	8	12	16
Positional Accuracy*							
1.0 mm lead	µm	30	45	75	—	—	—
2.0 mm lead		30	45	75	10	15	18
10.0 mm lead		35	50	80	—	—	—
Bi-directional Repeatability*							
1.0 mm lead	µm	±5.0	±5.0	±5.0	—	—	—
2.0 mm lead		±5.0	±5.0	±5.0	±1.5	±1.5	±1.5
10.0 mm lead		±10.0	±10.0	±10.0	—	—	—
Inertia (without motor & coupling)							
1.0 mm lead	10 ⁻⁷ kg-m ²	1.47	1.47	2.42	—	—	—
2.0 mm lead		1.62	1.62	2.68	4.19	4.19	6.08
10.0 mm lead		6.34	6.34	11.30	—	—	—
Screw Speed (max)	rps	20	20	20	50	50	50
Leadscrew Efficiency							
1.0 mm lead	%	40	40	40	—	—	—
2.0 mm lead		59	59	59	90	90	90
10.0 mm lead		78	78	78	—	—	—
Screw Diameter	mm	6.35	6.35	6.35	8.00	8.00	8.00
Bearing Coefficient of Friction		0.003	0.003	0.003	0.003	0.003	0.003
Unit Mass							
Table only	g	597	597	1003	694	694	1114
With 2-stack stepper		748	748	1154	845	845	1265
Carriage Mass (unloaded)	g	194	194	353	291	291	464

* Notes:

(1) Measured at the carriage center, 35 mm above the mounting surface @ 20 C with no load. Unit bolted to granite surface, flat to within 1 micron/300 mm.
 (2) Total accuracy and bi-directional repeatability over full travel (peak to peak).

(1) Measured at the carriage center, 35 mm above the mounting surface @ 20 C with no load. Unit bolted to granite surface, flat to within 1 micron/300 mm.
 (2) Total accuracy and bi-directional repeatability over full travel (peak to peak).
 (3) Repeatability valid with M21 servo motor.

Simple Configuration Digital Drive Options

All digital drives ordered in the MX80 part number configuration come set up with a motor file including electrical parameters to set continuous and peak currents, current loop compensation values, and default gain settings. Users will have the ability to override these parameters for special application requirements.

Tuning is easy and intuitive for users and is available via a variety of methods. The motor and loading information must be known by the drive to determine the baseline tuning gains. These are simple parameter entries the user can complete with the help of standard Parker supplied front-end software tools. Seamless integration of drives and controls ensures performance matched functionality of the completed motion system.

Servo & Microstepping Drives/Controllers

Parker servo and microstepping drives are the perfect drive solution to be paired with the MX80 family. We are happy to assist with the selection of a suitable drive.

Encoder Options

Order Codes: E2 E3 E4 E5

A non-contact linear optical encoder provides a quadrature output and offers resolution ranging from 10 nanometer to 5 micron. On the MX80L, the encoder is internal to the stage body. There is no increase to the footprint of the unit and no additional external cabling is required.

Plug & Play” Cable Options

Order Codes: CM02 CM03 CM04 CM05 CM06 CM07 CM08 CM09 CM10 CM11 CM12 CM13 CM15 CM17 CM18 CM19

“User convenience” is high on the list of cable attributes found in the MX80. The high-flex cabling and connectors are reliable, durable and offer easy hook-up for “plug and run” installation.

- **High-flex cables**
- **CE compliant connectors and shielding**
- **CE compliant ferrite beads**
- **Color coded jackets and labeling**
- **Connectors simplify installation**

Cable Connector Configuration

HD15M-VF 15 Pin HD-SUB Plug		HD15F-VLPR 15 Pin HD-SUB Rcpt	
Pin #	Function	Pin #	Function
1	Z+	1	GND
2	Z-	2	
3	GND	3	NO CONN
4	NO CONN	4	NO CONN
5	+5V	5	NO CONN
6	GND	6	+LIMIT
7	A-	7	-LIMIT
8	A+	8	HOME
9	HALL1	9	NO CONN
10	TEMP	10	NO CONN
11	B-	11	+24V to 560 Ohm Res
12	B+	12	NO CONN
13	HALL2	13	NO CONN
14	HALL3	14	NO CONN
15	NO CONN	15	NO CONN
HD15M-VF Connector compatible with IPA, Vix and Aries Feedback Connector		HD15F-VLPR Connector compatible with Vix Limit/Home Connector	

Home and Limit Sensor Options

Order Codes: H2L2 H2L3 H3L2 H3L3

Magnetic home and limit sensors are completely housed within the body of the stage. An innovative design adds functionality without sacrificing geometry. Sensor triggers can be easily adjusted over the travel. The output format is an open collector type capable of sinking up to 50 mA, and be set as N.O. or N.C.

For complete details on drive product features and specifications, please refer to the “Drives, Motors, Gearheads, & Controllers” section of this catalog.

Cleanroom Option

Order Codes: R2

Both precision and standard grade products can be prepared for cleanroom compatibility. Preparation involves material changes, element modification and cleanroom compatible lubricants. MX80L and MX80S stages with this option are class 10 cleanroom compatible. When applying an XY or XYZ combination in a cleanroom environment, moving wires need to be considered – please consult a Parker application engineer.

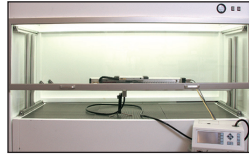

Low ESD Coating Option

(Available via customization only)

An optional low ESD electroless nickel or Armoloy coating is offered for improved electrical conductivity, providing a low resistance to ground path for electric discharge.

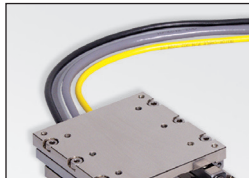

Environmental Protection Option

All units are standard with low luster black anodize finish. Other protective coatings are available to meet your application requirements.

System Orthogonality Option

(Available via customization only)

In any multi-axis positioning system, the perpendicular alignment of the axes must be clearly specified. “Degree of orthogonality” defines the perpendicular alignment of axis one to another. The MX80s offer two choices for orthogonality. As standard, perpendicularity is held to within 60 arc seconds. For more exacting applications the MX80 can be optioned for 15 arc seconds orthogonality.

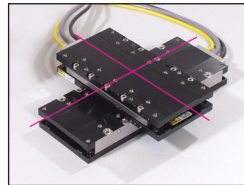

Z-Axis Bracket Accessory

Lightweight aluminum Z-brackets are available for easy construction of vertical axis combinations.

Standard Model Part Numbers:

25 & 50 mm: 002-2238-01
100 mm: 002-2240-01

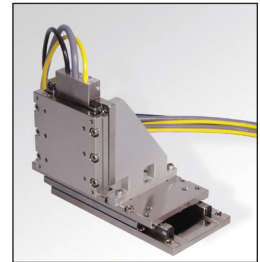

ORDERING INFORMATION

MX80S

Fill in an order code from each of the numbered fields to create a complete model order code.

① ② ③ ④ ⑤ ⑥ ⑦ ⑧ ⑨ ⑩ ⑪ ⑫ ⑬ ⑭ ⑮

Order Example: MX80S T04 M P K – D1 M1 H3L3 CM12 E1 Z1 R1 A11 X1 S1

- ① **Series**
MX80S
- ② **Travel – mm**
T01 25
T02 50
T03 100
- ③ **Mounting**
M Metric
- ④ **Grade**
S Standard
P Precision*
* Must order E3 or E4 Digital Option to meet catalog specification.
- ⑤ **Bearing Type**
K ACS Cross Roller
- ⑥ **Drive Type**
D1 1 mm Leadscrew ⁽¹⁾
D2 2 mm Leadscrew ⁽¹⁾
D3 10 mm Leadscrew ^(1,3)
D6 2 mm Ballscrew ^(2,3)
(1) Standard grade only (2) Precision grade only
(3) Not available with 1- or 2-stack stepper motor.
- ⑦ **Motor**
M0 No motor, flange, coupling
M15 Stepper, 2 stack, NEMA 11
M16 Stepper, 3 stack, NEMA 11
M21 Servo, 1 stack, NEMA 16
N11 NEMA 11 mtr mount with 5mm bore coupling
N16 BE16 mtr mount with .250" bore coupling
N17 Nema 17 mtr mount with 5 mm bore coupling
N31 PM-FAL mtr mount with 8 mm bore coupling
- ⑧ **Home/Limit Switch***
H1L1 None
H2L2 N.C. Home/N.C. Limit
H2L3 N.C. Home/N.O. Limit
H3L2 N.O. Home/N.C. Limit
H3L3 N.O. Home/N.O. Limit
*NC = Normally Closed; NO = Normally Open
- ⑨ **Cable Options (High-flex)**
CM01 None
CM02 Limits (only) w/Flying Leads (1m)
CM03 Limits (only) w/Flying Leads (3m)
CM04 Limit cable (1m) only w HD15M-VL connector
CM05 Limit cable (3m) only w/HD15M-VL connector
CM06 Stepper Motor (Flying Leads) & Limits with HD15M-VL Connector (1m)
- ⑩ **Digital Option**
E1 None
E2 1.0 µm Resolution
E3 0.5 µm Resolution
E4 0.1 µm Resolution
E5 5.0 µm Resolution
- ⑪ **Z Channel Location**
Z1 None
Z3 Center Position
- ⑫ **Environmental**
R1 Standard Finish (black anodized)
R2 Cleanroom Prep (Only available if Drive Type D6 (2mm ballscrew) is selected)
- ⑬ **Digital Drive**
A1 No Drive
- ⑭ **Axis Designator**
S1 None (single-axis)
S2* X-axis base unit (cables @ 12 o'clock)
S3* Y-axis 60 arc-sec (cables @ 3 o'clock)
S4* Y-axis 60 arc-sec (cables @ 9 o'clock)
S5* Y-axis 15 arc-sec (cables @ 3 o'clock)
S6* Y-axis 15 arc-sec (cables @ 9 o'clock)
*Consult factory for multi-axis pinning options and quotation
- ⑮ **Required Designator**
X1

- CM07 Stepper Motor (Flying Leads) & Limits with HD15M-VL Connector (3m)
 - CM08 Stepper Motor (Flying Leads) No Limits (1m)
 - CM09 Stepper Motor (Flying Leads) No Limits (3m)
 - CM10 Stepper Motor (Flying Leads) & Limits Flying Leads (1m)
 - CM11 Stepper Motor (Flying Leads) & Limits Flying Leads (3m)
 - CM12 Stepper Motor (Flying Leads) No Limits Flying Leads (1m)
 - CM13 Stepper Motor (Flying Leads) No Limits Flying Leads (3m)
 - CM15 Servo Motor & Limits with HD15M-VF & HD15M-VL Connectors (3m)
 - CM17 Servo Motor & No Limits with HD15M-VF Connector (3m)
 - CM18 Stepper Motor (A4-Mtr) (Flying Leads) & Limits Flying Leads (1m)
 - CM19 Stepper Motor (A4-Mtr) (Flying Leads) & Limits Flying Leads (3m)
- Notes - HD15M-VF Connector compatible with Vix Feedback Connector
HD15M-VL Connector compatible with Vix Limit/Home Connector
A4-MTR Motor Connector compatible with ACR7xT Multi-Axis Controller
Vix and E-Drive Accept Stepper Motor with Flying Leads

Cable Options continued next column