

*UM, UMM, UMQ & UMMQ Series
Installation and Operating Manual*



OMRON Scientific Technologies Inc.

Manufacturing and Sales Office

6550 Dumbarton Circle

Fremont, CA 94555 USA

1 / 888 / 510-4357

Tel: 510/608-3400

Fax: 510/744-1442

www.sti.com

UM, UMM, UMQ, & UMMQ Series

Contents

Section 1— <i>Important Safety Warnings</i>	page 4
1.1— <i>About the Universal Safety Mats</i>	page 4
Section 2— <i>Introduction</i>	page 6
2.1— <i>What a Safety Mat Does</i>	page 6
2.2— <i>Theory of Operation</i>	page 6
Section 3— <i>Mat Construction</i>	page 7
3.1— <i>Internal Assembly</i>	page 7
3.2— <i>Cables</i>	page 7
Section 4— <i>Bulk Trim & Trim Assemblies</i>	page 8
4.1— <i>Trim</i>	page 8
4.2— <i>Two Part Ramp Trim with Yellow PVC Cover: (TKM)</i>	page 9
4.3— <i>Two Part Ramp Trim with PVC Cover & Molded Corners: (TKC)</i>	page 10
4.4— <i>Two Part Ramp Trim with Aluminum Cover: (TKAT)</i>	page 11
4.5— <i>Single Part Aluminum Ramp Trim: (TKA)</i>	page 12
4.6— <i>Aluminum Blunt Trim: (UMBT)</i>	page 13
4.7— <i>Active Joining Trim (UMJS)</i>	page 14
Section 5— <i>Selecting The Safety Mat Size</i>	page 16
5.1— <i>About the Mat Size</i>	page 16
5.2— <i>Active Mat Surface</i>	page 16
Section 6— <i>Safety Mounting Distance</i>	page 17
6.1— <i>Determining the Safe Mounting Distance</i>	page 17
6.2— <i>Theory of Operation</i>	page 17
6.2— <i>Safety Distance Calculation</i>	page 17
6.3— <i>ANSI Minimum Safe Distance Formula</i>	page 17
6.3.1— <i>Safe Mounting Distance Example</i>	page 19

6.5—*Installation* page 20

 6.5.1—*Surface Preparation* page 20

 6.5.2—*Proper Care of the Safety Mat Cables* page 20

6.4—*Safety Mat Mounting Trim* page 19

Section 7—*Safety Mat Installation* page 20

 7.1—*Proper Procedure* page 20

 7.1.1—*Surface Preparation* page 20

 7.1.2—*Lifting and Carrying the Universal Safety Mat* page 20

 7.1.3—*Proper Care of the Universal Safety Mat Cables* page 21

 7.1.4—*Securing the Universal Safety Mat to the Floor* page 21

 7.2—*UMQ Series Mat Installation* page 8

 7.3—*Cable Attachment* page 22

 7.4—*Wire Cutouts* page 23

 7.4.1—*Wire Cutouts for the Joining Trim* page 23

 7.4.2—*Wire Cutouts for the Ramp Trim* page 23

 7.4.3—*Wire Cutout Pictures* page 24

 7.5—*Operation of Air Equalization Valve* page 25

 7.5.1—*Purpose* page 25

 7.5.2—*Use* page 25

Section 8—*Warranty* page 26

 8.1—*OMRON STI Product Warranty Information* page 26

Section 9—*Installation Example* page 27

 9.1—*Example of Good Mat Installation* page 27

Figures

Figure 3-1— <i>Mat Measurement</i>	page 7
Figure 3-2— <i>Cable Pin-outs</i>	page 8
Figure 3-3— <i>“Y” Connector Pinouts</i>	page 8
Figure 4-1— <i>Dimensions and Installation of 2-Part Aluminum Base, PVC Cover with Mitered Corners</i>	page 9
Figure 4-2— <i>Dimensions and Installation Information for 2-Part Aluminum Base, PVC Cover with Molded Corners</i>	page 10
Figure 4-3— <i>Dimensions and Installation of 2-Part Aluminum Base, Aluminum Cover with Mitered Corners</i>	page 11
Figure 4-4— <i>Dimensional and Installation Information for Aluminum Ramp Trim</i>	page 12
Figure 4-5— <i>Dimensional Information (Trim Only)</i>	page 12
Figure 4-6— <i>Blunt Trim Installation Information</i>	page 13
Figure 4-7— <i>Blunt Trim Dimensional Information</i>	page 13
Figure 4-8— <i>Picture Below Shows Joining Trim NOT Stepped On</i>	page 14
Figure 4-9— <i>Picture Above Shows Joining Trim Stepped On</i>	page 14
Figure 6-1— <i>Safety Mounting Distance</i>	page 18
Figure 7-1— <i>Picture of Mats, Trims and Cables</i>	page 20
Figure 7-2— <i>Carrying the Mat</i>	page 21
Figure 7-3— <i>Safety Mat without the Cable Attached</i>	page 22
Figure 7-4— <i>Safety Mat with Cable attached</i>	page 22
Figure 7-5— <i>Joining Trim Wire Cutouts</i>	page 23
Figure 7-6— <i>Ramp Trim Wire Cutout</i>	page 23
Figure 7-7— <i>Picture of Joining Trim Cutout where Joining Trim enters Ramp Trim</i>	page 24
Figure 7-8— <i>Picture of Joining Trim Cutout where Joining Trim enters Joining Trim</i>	page 24
Figure 7-9— <i>Instruction for Air Equalization Valve</i>	page 25
Figure 9-1— <i>Good Mat Installation</i>	page 27

Tables

Table 3-1— <i>UM & UMM Series Mats Cable Connections</i>	page 7
--	--------

1 IMPORTANT SAFETY WARNINGS

▲ WARNING! Read and understand this section prior to installing the Universal Safety Mat and Controller system.

1.1 ABOUT THE UNIVERSAL SAFETY MATS

A presence sensing mat and a controller are general purpose presence sensing devices designed to guard personnel working around moving machinery. The use of this type of guarding system is regulated by government safety agencies. Please contact Omron STI in California, USA at 510-608-3400 for additional assistance.

Whether a specific machine or Universal Safety Mat and Controller installation fully complies with government regulations, depends on several items including: the proper application, installation, maintenance and operation of the Universal Safety Mats and Controller. These items are the sole responsibility of the purchaser, installer and employer.

The employer is also responsible for the selection and training of the personnel necessary to properly install, operate and maintain the machine and its safety systems. For example, the Universal Safety Mats and Controller should be installed, checked out and maintained only by a qualified person.

The user is that person(s) identified and designated by the employer as being appropriately trained and qualified to perform a specific procedure. Often the user is the installer, die setter, electrician, maintenance personnel, supervisor, or foreman, etc., involved with the setup, test and checkout of the machine and all safety devices.

Definition of Qualified Person

“A person who, by possession of a recognized degree in an applicable field or a certificate of professional standing, or who by extensive knowledge, training, and experience, has successfully demonstrated the ability to solve or resolve problems relating to the subject matter and work.(Reference ASME B30.2-2001)”

The equipment operator must receive specific, proper training on exactly which equipment is protected by the Universal Safety Mats and Controller, the equipment’s operating controls, warning signs and safety instructions. The equipment operator must thoroughly understand and follow the company’s safety rules and always use the safeguards and proper hand tools provided by the employer. The equipment operator must notify management if the equipment, tooling or safety devices are not operating properly. Never use the equipment if it or the related safety equipment is not in proper working order.

The following additional requirements must be met before using the Universal Safety Mat & Controller System:

- The equipment on which the Universal Safety Mat and Controller are installed must be capable of stopping motion anywhere in its stroke or cycle.
- Do not use a Universal Safety Mat and Controller on any device with inconsistent stopping time or inadequate control devices or mechanisms.
- Do not use where the environment, such as corrosive chemicals, may degrade the effectiveness of the Universal Safety Mat and/or Controller.

- When a Universal Safety Mat and Controller are installed on a machine or other piece of equipment as a Safety Device, the employer has the responsibility to insure that all applicable federal, state and local Occupational Safety and Health Act (OSHA) requirements and other such rules, codes and regulations are satisfied.
- All safety-related machine control circuit elements, including pneumatic, electric or hydraulic controls, must be control reliable as defined by ANSI B11.19-2003, 3.14. All other machinery or equipment must meet OSHA Standard 1910.212 on general machine guarding plus any other applicable regulations, codes and standards.
- Additional guarding such as safety light curtains or mechanical guards may be required if the presence sensing mat and controller do not protect all areas of entry to the point of operation hazard.
- Do not use a Universal Safety Mat and Controller to initiate machine or equipment motion.
- All brakes and other stopping mechanisms must be inspected regularly to ensure proper working order. If the stop mechanisms and associated controls are not working properly, the machine may not stop safely even though the Universal Safety Mat and Controller are functioning properly.
- Only qualified personnel must install and test the Universal Safety Mats and Controller. Do not perform any test or repairs other than those outlined in this manual. All electrical wiring must be installed in accordance with local electrical codes and regulations.

The user must follow all procedures in this manual for proper operation of the Universal Safety Mats and Controller.

The enforcement of these requirements is beyond the control of Omron STI. The employer has the sole responsibility to follow the preceding requirements and any procedures, conditions and requirements specific to his machinery.

2 INTRODUCTION

▲ WARNING! Read and understand this manual prior to installing the Safety Mat system.

2.1 WHAT A SAFETY MAT DOES

Universal Safety Mats combined with an Omron STI safety mat controller, provide personnel safeguards around hazardous machinery.

The Universal Safety Mat monitors ingress to the covered hazardous area and allows unimpeded access for machinery, handling equipment and operators.

2.2 THEORY OF OPERATION

Multiple Safety Mats may be wired in series to form a complete floor level guarding system. Each 4-wire Universal Safety Mat operates on a low-power DC, signal. A signal is transmitted through the upper and lower plates separately through the two wires connected to each plate these signals are monitored by the Safety Mat Controller.

When the weight on the Universal Safety Mat is **insufficient** to activate the mat, the signals are unimpaired, the output relays in the controller are energized permitting the guarded machine to run.

When sufficient pressure is applied to the active mat area, the conductive plates touch causing the output relays in the controller to de-energize and a stop signal is sent to the guarded machine.

If a wire should break, or separate from a plate, or become disconnected from the controller the Safety Outputs in the controller will de-energize and a stop signal will be sent. If the Universal Safety Mat is punctured, the plates **may** short together in a manner similar to the mat being stepped on. The controller will not restart until the damaged mat is replaced.

3 MAT CONSTRUCTION

3.1 INTERNAL ASSEMBLY

The internal switch consists of two sheets of specially flattened, 24-gauge galvanealed steel. This assembly is then sealed in a chemically engineered, PVC (Polyvinyl Chloride) Resin. This configuration insures high resistance to impact, load, rust and moisture. The active area extends to within 6.25mm (0.25 in.) of the overall top surface length and width dimensions of the safety mat.

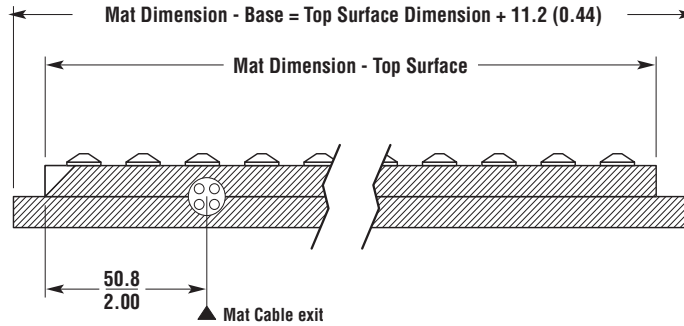

Mat Cable exits on the side indicated by the first dimension in the model number
 i.e. UM5-1254, Cable exits 12" dimension
 i.e. UM5-4824, Cable exits 48" dimension

Figure 3-1 Mat Measurement

3.2 CABLES

The Universal Safety Mat has a four-conductor cable with a PVC (Polyvinyl Chloride) jacket. Each individual conductor is 18 AWG, 16-strand, 300VAC. The cable has a 4-pin quick-disconnect fitting on the end for easy installation and replacement of the mat. The individual conductors inside the cable are color coded. The black and blue conductors are connected to the bottom electrode plate. The brown and white conductors are connected to the top electrode plate. Standard cable length is 5 meters, other cable lengths are available.

Terminal Connections for Mats to STI Controllers			
Mat Conductor Color	MC3	MC4	MC6
Brown	M12	Term. 1 - 6 Brown	Term. 1 - 6 Brown
Black	M11	Term. 1 - 6 Black	Term. 1 - 6 Black
Blue	M21	Term. 1 - 6 Blue	Term. 1 - 6 Blue
White	M22	Term. 1 - 6 White	Term. 1 - 6 White

Table 3-1 UM & UMM Series Mats Cable Connections

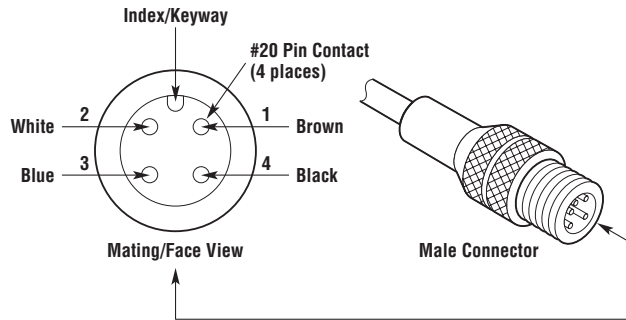

Figure 3-2 Cable Pin-outs

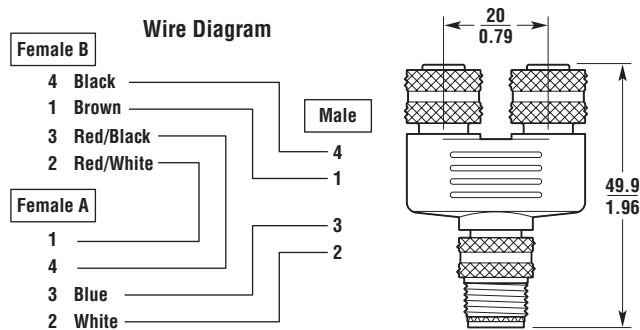

Figure 3-3 "Y" Connector Pinouts

4 BULK TRIM & TRIM ASSEMBLIES

4

4.1 TRIM

- ▲ **PERIMETER WARNING!** Employees must be instructed that the perimeter trim is not an active sensing surface. Stepping only on the perimeter trim will not send a stop signal to the guarded machine.

Perimeter trim is used to provide mechanical protection for the mat cables and to fasten the mat(s) in place as required by ANSI B11.19-2003.

Several types of perimeter trim are available as described later in this document.

European norm EN 1760-1:1997, Section 4.17 states, in part, "Where there is a danger that a person can trip on the outside edge(s) of a sensor or sensor covering, a suitable ramp shall be provided. The slope of the ramp shall not exceed 20 degrees from the horizontal." Typically Omron STI trim is sloped at 19 degrees and measures 2 1/2 inches (62.5mm) wide.

The following pictures show the various versions of the perimeter trim and joining trim that are currently available from STI, and show the typical installation dimensional details.

The following pages show details of the available Omron STI Trim Assemblies.

Items shown include:

- TKM - 2 Part Ramp Trim with wiring Channel and PVC Cover / Mitered Corners
- TKC - 2 Part Ramp Trim with wiring Channel and PVC Cover / Molded Corners
- TKAT - 2 Part Ramp Trim with wiring Channel and Aluminum Cover / Mitered Corners
- TKA - Single Part Aluminum Ramp Trim with wiring Channel / Mitered Corners
- UMBT - Blunt Trim with wiring Channel
- UMJS - Standard Joining Trim with wiring Channel / PVC Cover

4.2 TWO PART RAMP TRIM WITH YELLOW PVC COVER: (TKM)

This trim provides a convenient wiring channel for up to 4 mat cables. Wires can be easily installed in the base and the cover installed after the system has been checked for proper operation. **This is the most commonly used trim.**

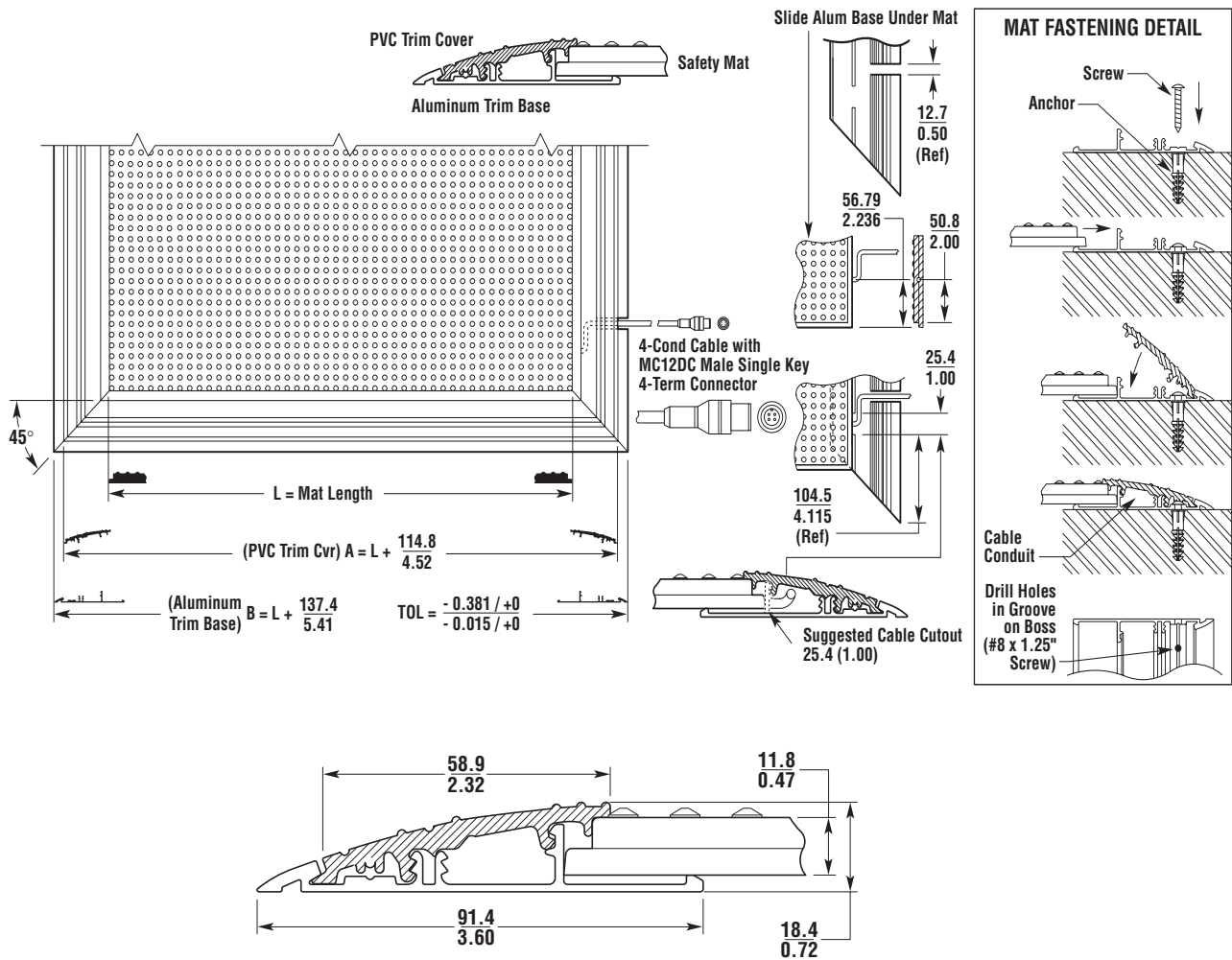

Figure 4-1 Dimensions and Installation of 2-Part Aluminum Base, PVC Cover with Mitered Corners

4.3 TWO PART RAMP TRIM WITH PVC COVER & MOLDED CORNERS: (TKC)

This trim provides a convenient wiring channel for up to 4 mat cables and the molded corners make field cutting of trim easier. Care must be taken where wires are routed around the molded corners as these corners are fastened over the wiring.

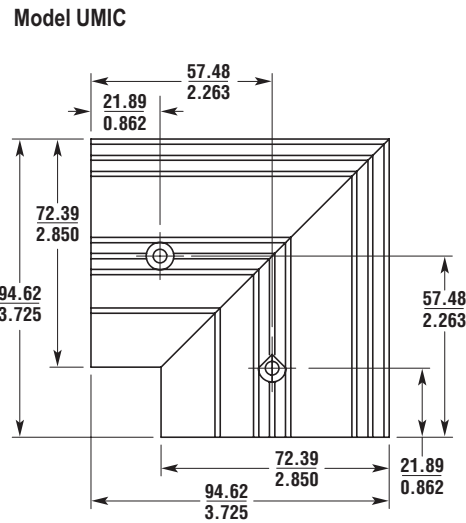
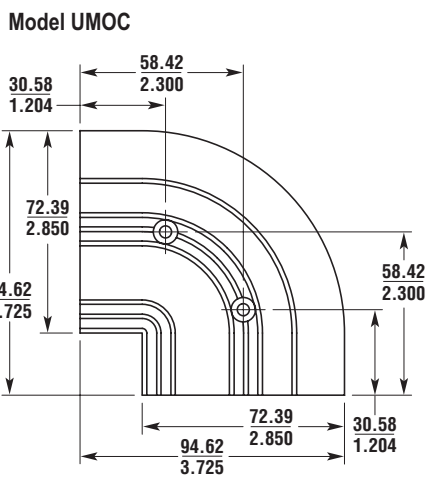
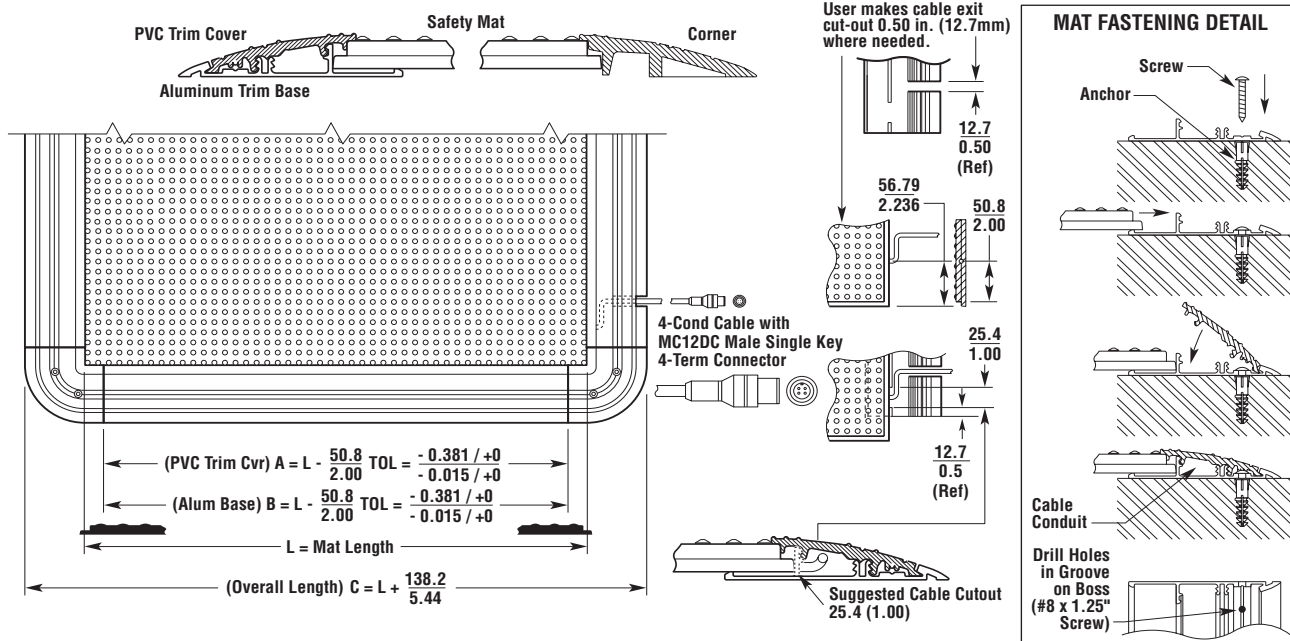

Figure 4-2 Dimensions and Installation Information for 2-Part Aluminum Base, PVC Cover with Molded Corners

4.4 TWO PART RAMP TRIM WITH ALUMINUM COVER: (TKAT)

This trim provides a convenient wiring channel for up to 4 mat cables and is used where additional protection may be required for mat wiring. Wires can be easily installed in the base and the cover installed after the system has been checked for proper operation. The aluminum top is fastened with screws provided.

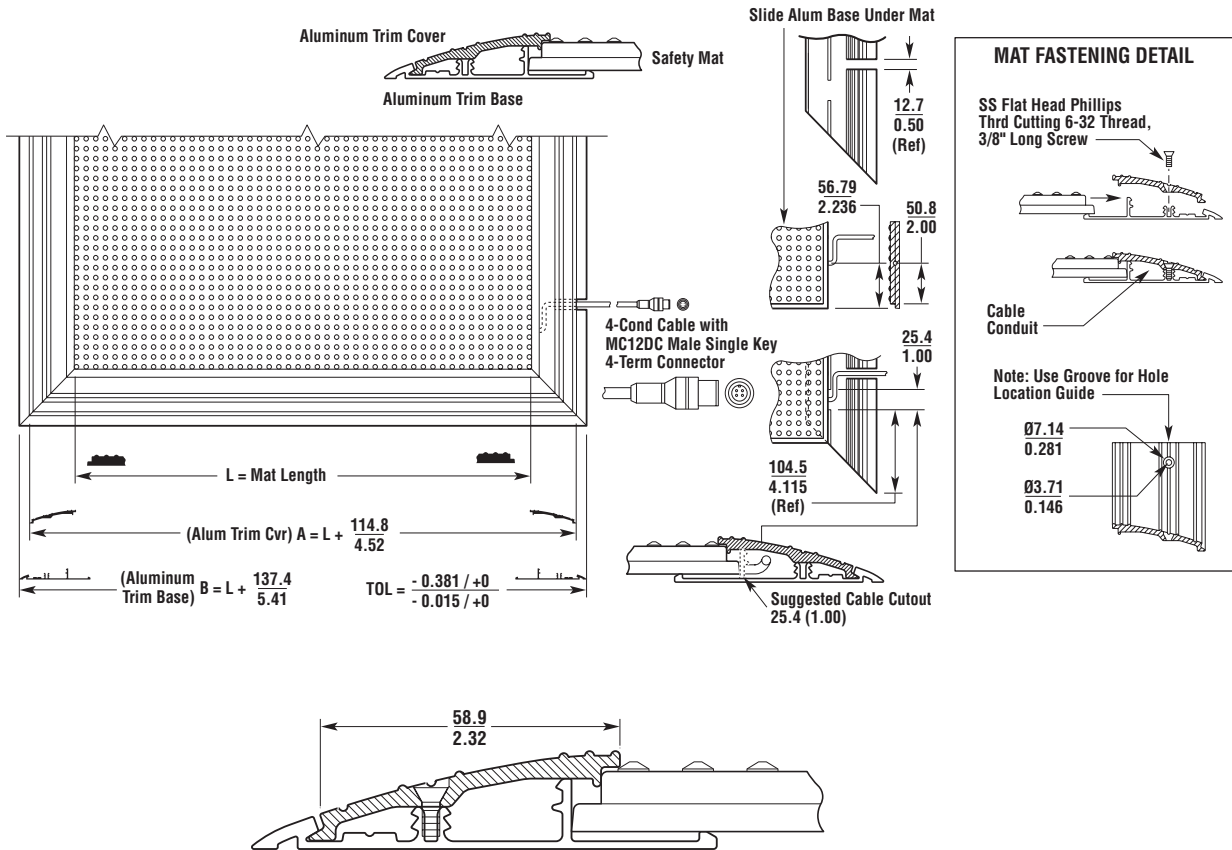

Figure 4-3 Dimensions and Installation of 2-Part Aluminum Base, Aluminum Cover with Mitered Corners

4.5 SINGLE PART ALUMINUM RAMP TRIM: (TKA)

This trim is used where additional mechanical protection is required for the mat wiring. When using this trim it is very important to take care to ensure that the mat wiring is not damaged when the trim is fastened to the floor.

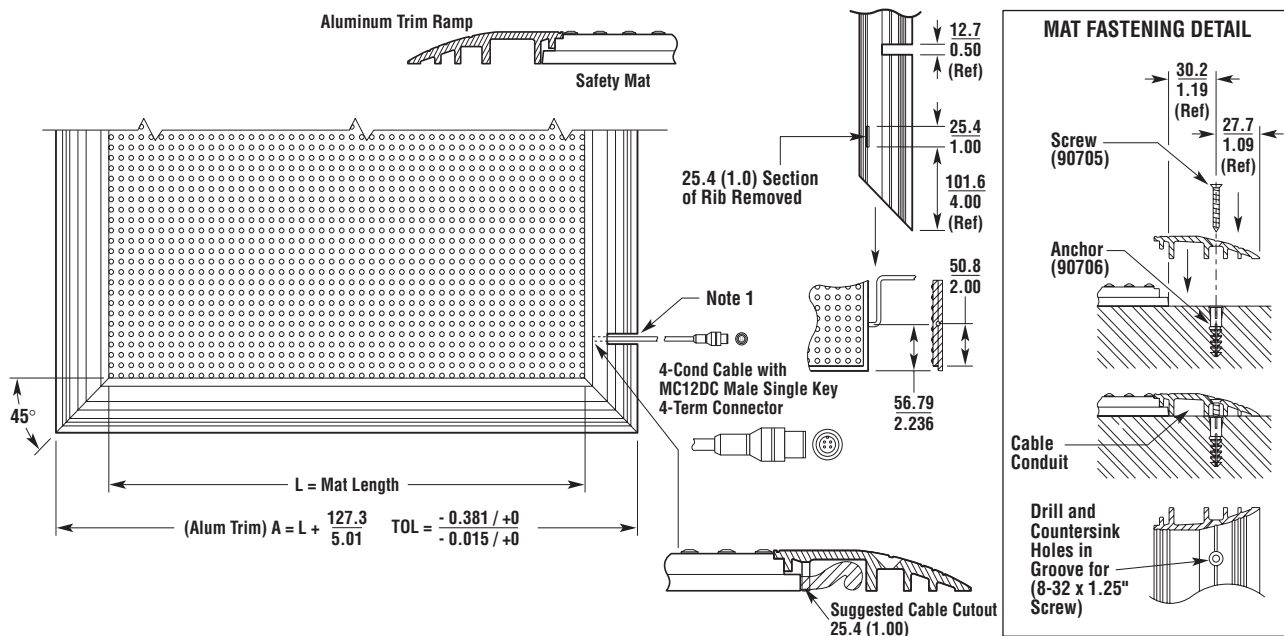

Figure 4-4 Dimensional and Installation Information for Aluminum Ramp Trim

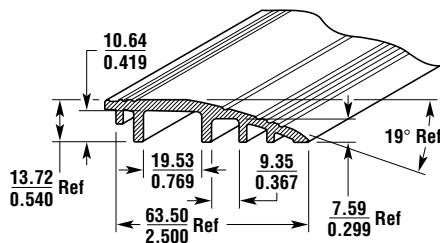

Figure 4-5 Dimensional Information (Trim Only)

4.6 ALUMINUM BLUNT TRIM: (UMBT)

Blunt Trim is 1 in. wide and should be used only in installations where a tripping hazard does not exist, such as against a wall, machine or mechanical guard. When using this trim it is very important to take care to ensure that the mat wiring is not damaged when the trim is fastened to the floor.

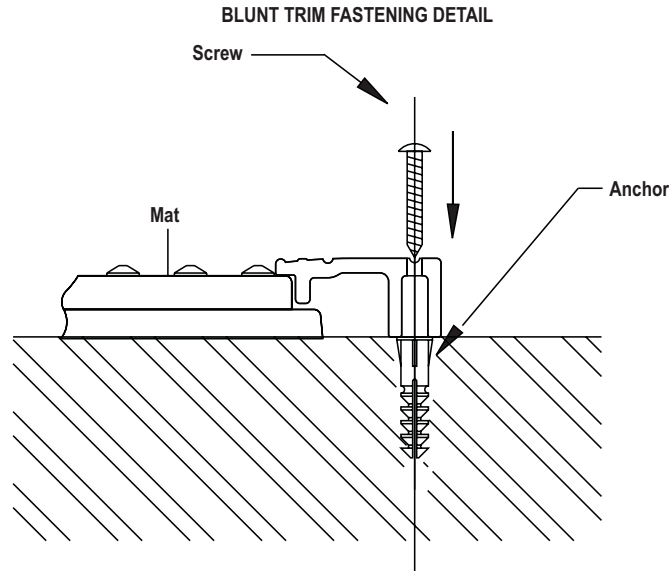

Figure 4-6 Blunt Trim Installation Information

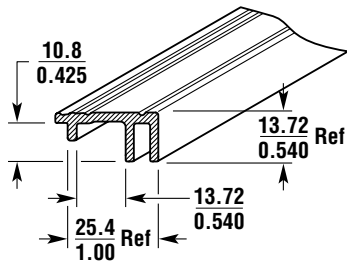

Figure 4-7 Blunt Trim Dimensional Information

4.7 ACTIVE JOINING TRIM (UMJS)

When multiple Universal Safety Mats are required to cover an area, Active Joining Trim is required. Active Joining Trim is comprised of two parts, the Active Joining Trim Base and the Joining Trim Cover.

Active Joining Trim is cut to be installed under and between two or more adjacent safety mats. It serves the dual purpose of creating an active joint between mats and as a wireway for mat cables. Active Joining Trim works by transferring the weight of an object or personnel beyond the 1/4 in. (6.25mm) inactive area along the edge of each mat to the active area of either one or both mats comprising the joint.

The drawing below details this joining trim.

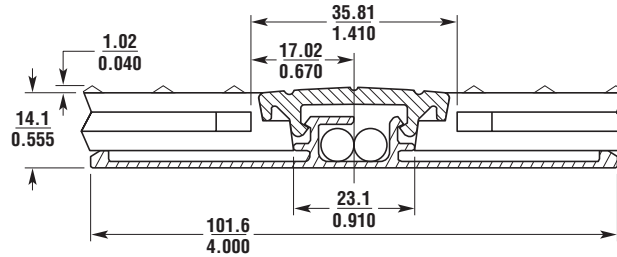

Figure 4-8 Picture Below Shows Joining Trim NOT Stepped On

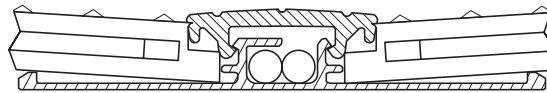

Figure 4-9 Picture Above Shows Joining Trim Stepped On

This page is intentionally left blank.

5 SELECTING THE SAFETY MAT SIZE

5

5.1 ABOUT THE MAT SIZE

According to ANSI B11.19-2003, “the size of the safety mat should be large enough to prevent entry into the hazardous area. In some cases, this may require the use of more than one mat or additional safeguarding.” See *Figure 6-1*.

The safety mat must be of sufficient size to detect entry by an operator or others into a hazardous area. Universal safety mats are available in a variety of standard sizes. You can visit the Omron STI web site www.sti.com for sizes and availability. If you need to identify an existing Universal safety mat, read in the Omron STI catalog for instructions on how to determine the model number, or call Omron STI for assistance. Knowing the distance from the hazardous area of the machine that must be covered with safety mats is critical to a safe installation.

5.2 ACTIVE MAT SURFACE

Universal Safety Mats are designed to be secured to the mounting surface with perimeter trim. The mat has an inactive (non-sensing) area 1/4 in. (6.35mm) wide around the perimeter of the mat at the edge. This inactive edge is installed under the perimeter trim such that, with the trim installed, the exposed surface of the mat is active.

Two or more mats placed adjacent to each other to form a large sensing area must use the Active Joining Trim. The proper installation of the Active Joining Trim will create a fully active sensing area in accordance with EN1760-1:1997.

6 SAFETY MOUNTING DISTANCE

6.1 DETERMINING THE SAFE MOUNTING DISTANCE

Presence sensing mats combined with a safety mat controller improve productivity while providing access guarding. Less downtime occurs because it is not necessary to set up or remove mechanical safety barriers during operation and maintenance.

Presence sensing mats and controls are used where perimeter access guarding is required, such as around robots, manufacturing work cells, food processing equipment and automated assembly equipment.

Mats and controllers should be designed to meet the applicable sections of ANSI B11.19-2003, OSHA 1910.212 and EN 1760-1:1997.

6.2 SAFETY DISTANCE CALCULATION

The first and by far the most important consideration is the calculation of the safety distance. There is a minimum mat size that should be placed between a worker and a hazardous motion. Many users will "eyeball" the application, look at the area where a machine operator would stand and say, "that looks like it needs a 24-inch wide mat." It may not be enough.

In standard B11.19 the American National Standards Institute (ANSI) states that, "The safety mat device shall be fixed at a location so that the effective sensing surface prevents individuals from reaching the hazard(s) during the hazardous portion of the machine cycle."

6.3 ANSI MINIMUM SAFE DISTANCE FORMULA

The basis for the following information is ANSI standard B11.19-2003.

The ANSI formula consists of:

$$D_s = K (T_s + T_c + T_r + T_{spm}) + D_{pf}$$

Where:

D_s = The minimum safe distance, in inches, between the outside edge of the safety mat and the nearest point of operation hazard.

K = The maximum speed at which an individual can approach the hazard, expressed in inches per second.

To quote ANSI B11.19-2003, "The factor K is the speed constant and includes hand and body movements of an individual approaching a hazard area. The following factors should be considered when determining K :

- a) Hand and arm movement;
- b) Twisting of the body or shoulder, or bending at the waist;
- c) Walking or running.

One of the accepted values for K is the hand speed constant (it is usually considered as the horizontal motion of the hand and arm while seated). Its common value is 63 in./s although other values (typically higher) are also used. The hand speed constant does not include other body

movements, which can affect the actual approach speed. Consideration of the above factors should be included when determining the speed constant for a given application.”

T_s = The total time that it takes, in seconds, for the hazardous motion to stop, or for the hazardous portion of the machine cycle to be completed. Note that different machine types have different stopping methods and mechanisms.

Informative Annex D of ANSI B11.19-2003 contains excellent information on these considerations and factors.

T_c = The response time, in seconds of the machine control circuit to activate the machine’s brake.

NOTE: $T_s + T_c$ are usually measured together by a stopping performance monitor.

T_r = The response time, in seconds, of the safety mat system. This is provided in the installation manual.

T_{spm} = The additional stopping time, in seconds, allowed by the stopping performance monitor before it detects stop time deterioration. A stopping performance monitor will halt the machine when the stop time of the machinery exceeds the set limit. This indicates that excessive brake wear has occurred.

What should you do if your machine does not have a stopping performance monitor? Add a percentage increase factor to the measured stop time ($T_s + T_c$) to allow for braking system wear. For example, stopping performance monitors usually add an extra 20% to the measured stop time. Omron STI recommends that you contact the manufacturer of your machine for guidance in selecting a percentage increase factor.

D_{pf} = The added distance, in inches, due to the depth penetration factor from according to Annex D of ANSI B11.19-2003, for ground level devices which can be reached over (safety mats) this distance is 48 inches.

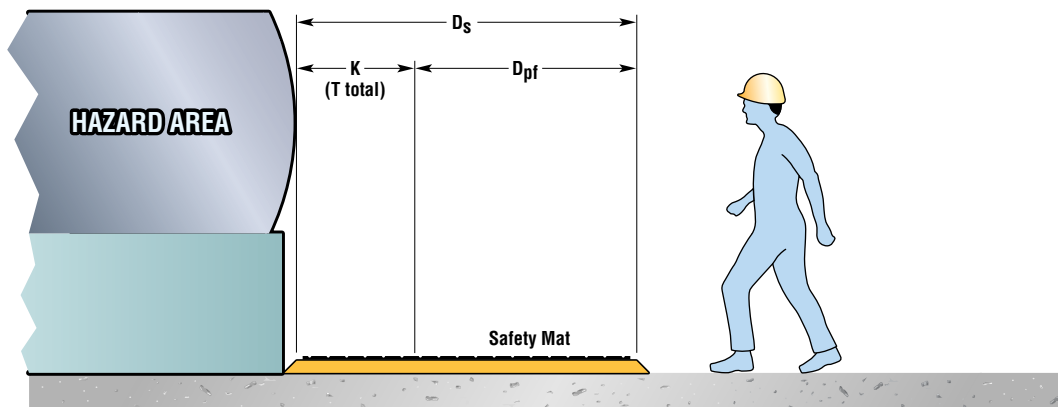

Figure 6-1 Safety Mounting Distance

6.3.1 SAFE MOUNTING DISTANCE EXAMPLE

Presume a machine has a stopping time ($T_s + T_c$) of 0.200 seconds. This includes the response time of both the brake mechanism and the control circuits. The brake monitor is set for 0.240 seconds. The response time of the safety mat system is 30 mS.

Determine T_{spm} and D_{pf} . From the stopping performance monitor set point:

T_{spm} = stopping performance monitor set point - ($T_s + T_c$)

T_{spm} = 0.240 sec. - 0.200 sec.

T_{spm} = 0.040 sec.

As given from ANSI B11.19-2003, Annex D, D_{pf} = 48 inches.

Now, everything needed is available. The formula is:

$D_s = K \times (T_s + T_c + T_r + T_{spm}) + D_{pf}$

Substituting our values:

$D_s = 63 \text{ in./sec.} \times (0.200 \text{ sec.} + 0.010 \text{ sec.} + 0.040 \text{ sec.}) + 48 \text{ in.}$

Add the values in the parentheses first:

$D_s = 63 \text{ in./sec.} \times (0.250 \text{ sec.}) + 48 \text{ in.}$

Multiply the result in parentheses by 63:

$D_s = 15.75 \text{ in.} + 48 \text{ in.}$

Add the results:

$D_s = 63.75 \text{ in.} (1620 \text{ mm})$

6.4 SAFETY MAT MOUNTING TRIM

ANSI standard B11.19-2003 also states that, "*The user shall ensure that only authorized individuals may relocate the safety mat*" [clause 8.5.2.3]. Further explanatory information for this clause states that, "*Means to prevent inadvertent movement include, but are not limited to:*

- Secured edging;
- Secured trim;
- Fasteners;
- Recesses;
- Size and weight or large mats"

Perimeter trim can help with this requirement, but users need to be aware that not all perimeter trim is the same. Three of the most optimum types of trim include two-part perimeter ramp trim, blunt trim, and two-part joining trim.

Two-part perimeter ramp trim holds mat in place and simplifies installation by providing an aluminum base with channels for running cables, and a snap-on PVC cover. Blunt trim is used where a mat needs to be secured in place, but the edge being secured does not present a trip hazard. Two-part joining trim is used to create an active area between two adjacent mats.

7 SAFETY MAT INSTALLATION

- ▲ **WARNING:** Stacking safety mats after removal from packaging may affect the functionality of the mats.



Figure 7-1 Picture of Mats, Trims and Cables

Note! The Universal safety mat is a durable activating device, providing it is properly handled and installed. For dependable and long life of the safety mat, follow these instructions carefully.

7.1 PROPER PROCEDURE

7.1.1 SURFACE PREPARATION

The surface on which the safety mat(s) will be placed should be flat, smooth and free of debris. Any debris left under the mat may, in time, work its way through the PVC (Polyvinyl Chloride) housing and eventually contact the electrode assembly. This may affect the mechanical switching of the electrode assembly and will provide a path for moisture to enter the mat. These conditions may lead to a mat failure.

7.1.2 LIFTING AND CARRYING THE UNIVERSAL SAFETY MAT

Hold opposite sides, if possible, while lifting and carrying a safety mat. (Figure 7-2—*Carrying the Mat*) A slight bow along the length of the mat may be allowed. This will prevent the mat from bending across its width which could cause a bend or kink in the electrode assembly. Assistance may be required to lift, carry and install the larger safety mats. The weight of these mats varies from 5 pounds (2.3 kg) to over 100 pounds (45.25 Kg). The large size and flexibility of these mats can be awkward to lift and carry alone.

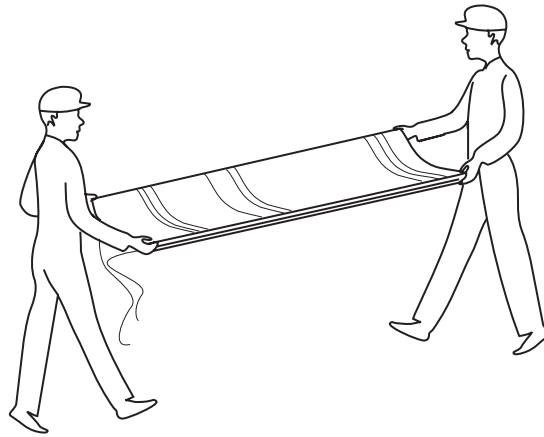

Figure 7-2 Carrying the Mat

7.1.3 PROPER CARE OF THE UNIVERSAL SAFETY MAT CABLES

After the mat is in place, use care in routing the mat cables to prevent damage to the insulation or damage to the internal wires. Make sure that the cable wire ways are free of burrs and sharp edges. If cables are to exit the trim, make sure that all notches or cutouts are large enough to allow the wiring to exit the trim without causing damage to the cables. See Section 4—*Bulk Trim & Trim Assemblies* for available trim.

7.1.4 SECURING THE UNIVERSAL SAFETY MAT TO THE FLOOR

ANSI B11.19-2003, Section 8.5.2.3 states, in part, *“The safety mat device shall be fixed at a location so that the effective sensing surface prevents individuals from reaching the hazard(s) during the hazardous portion of the machine cycle.”*

A safety mat **must be fixed** in position to prevent its removal or relocation. A relocated mat may not be in position to detect the operator, or other personnel, before they reach the hazard. A safety mat must not, of itself, create a hazard. Pre-drill mounting holes into the perimeter trim as shown on the drawing from *Figure 4-1* to *Figure 4-11*. Arrange the mat(s), cables, and trim system into the desired position. Check that all gaps are closed and all components of the sensing area are snug and properly oriented. Use the pre-drilled holes in perimeter trim as a template to mark drill points on the mounting surface. **Never drill through the safety mat!** Any holes in the mat will destroy the seal, impair the reliable operation of the mat and void the warranty. After marking drill points, remove perimeter trim and drill holes into mounting surface (use a 3/16 inch or 5mm bit). Insert the supplied plastic anchors into the mounting holes, position the perimeter trim pieces in alignment with the predrilled mounting holes and secure to the mounting surface using the supplied Phillips head screws.

7.2 UMQ SERIES MAT INSTALLATION

UMQ series mats are shipped without the cable attached. The mat connector assembly is covered to protect the contact area during shipment and installation. **To prevent contamination of the contact area, this covering material should not be removed until the cable is ready to be connected to the mat.** Cable assemblies are available in 5 and 10 meter lengths. The cable assembly includes the 3 stainless steel 6/32 mounting screws (attached to the cable assembly). **When properly installed the cable and connector assembly provide an IP67 seal to the mat and connector assembly.** UMQ series mats offer the ability to change cable lengths, without the hassle of having to determine the cable length at the time the order is placed.

7.3 CABLE ATTACHMENT

A protective cover is attached to the mat at the location of the mat cable connection.

Do Not Remove the protective cover from the contact area until ready to install the mat cable.

When attaching the cable DO NOT STAND ON THE MAT.

The torque applied to the 6/32 screws on the connector must be 12 IN.LB.



Figure 7-3 Safety Mat without the Cable Attached



Figure 7-4 Safety Mat with Cable attached.

The above picture shows safety mat with the cable attached, when the cable is attached, the mat profile is maintained.

7.4 WIRE CUTOUTS

7.4.1 WIRE CUTOUTS FOR THE JOINING TRIM

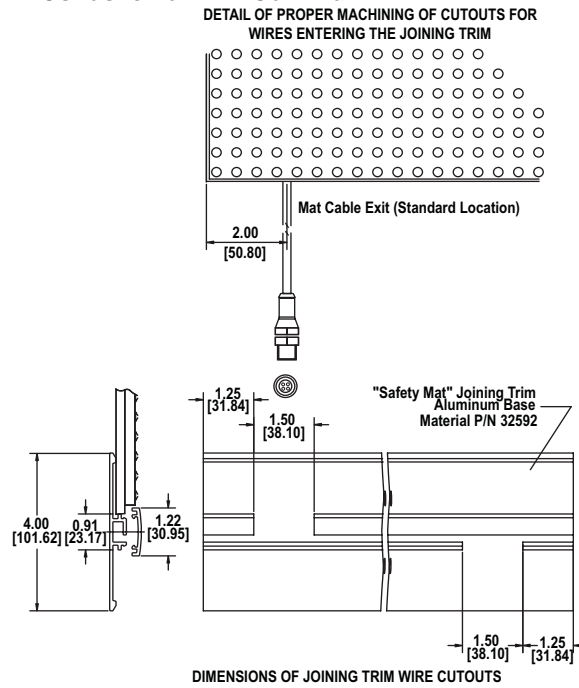

Figure 7-5 Joining Trim Wire Cutouts

7.4.2 WIRE CUTOUTS FOR THE RAMP TRIM

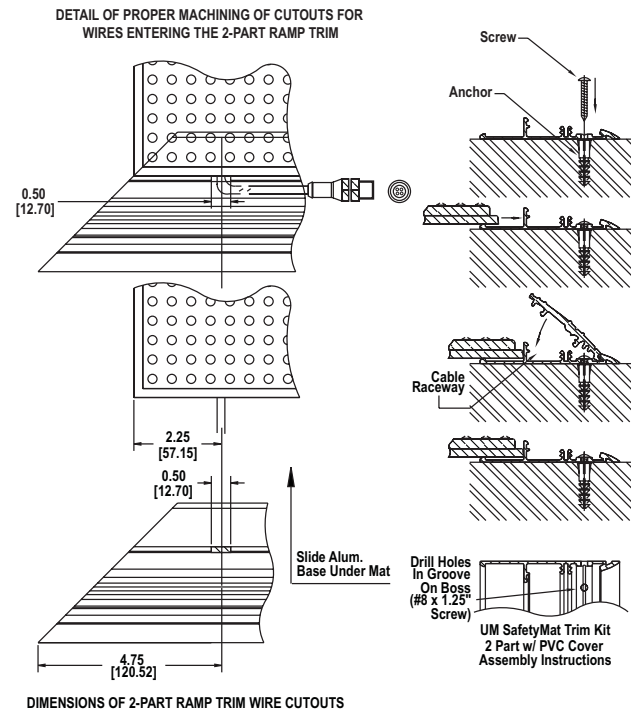

Figure 7-6 Ramp Trim Wire Cutout

7.4.3 WIRE CUTOUT PICTURES

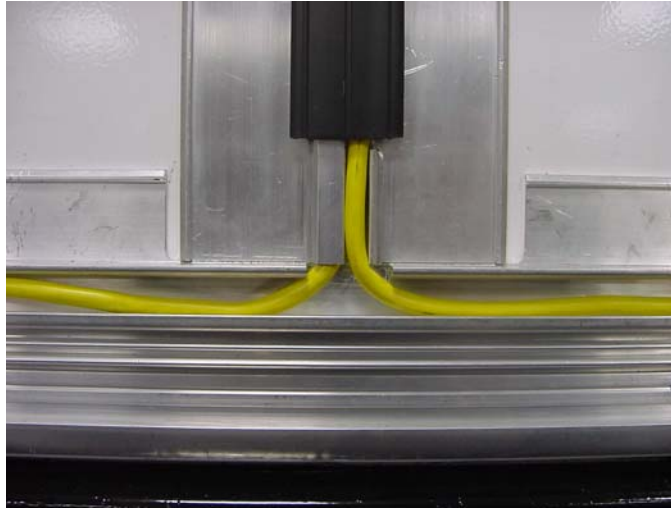

Figure 7-7 Picture of Joining Trim Cutout where Joining Trim enters Ramp Trim

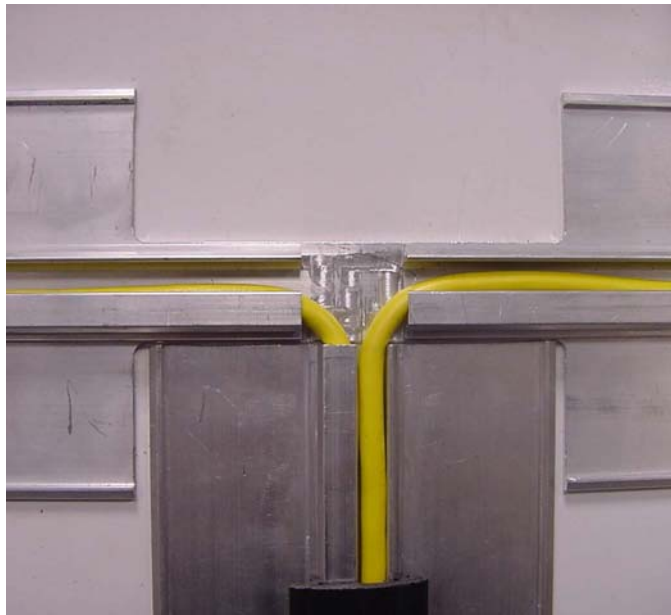

Figure 7-8 Picture of Joining Trim Cutout where Joining Trim enters Joining Trim

7.5 OPERATION OF AIR EQUALIZATION VALVE

This paragraph does not apply to the UMQ Series Mats

7.5.1 PURPOSE

To allow Safety Mat to equalize with outside atmosphere pressure to insure proper mat operation.

7.5.2 USE

After mats have been properly installed, clear any debris from area around air equalization valve. Open the air equalization valve with a standard screw driver by turning the air equalization valve screw 1 1/2 turns counter clockwise.

Do not remove screw.

Do not blow compressed air into the mat valve. This can cause internal damage to the mat and possible loss of the gasket used to seal the mat when the screw is tightened.

Allow the air equalization valve to remain open for a minimum of 30 seconds.

Do not stand on or allow objects to be on the safety mat during this process.

After the mat has been equalized, close the air equalization valve by turning the air equalization valve screw clockwise until securely closed.

Do not over tighten.

IMPORTANT NOTICE

Read instruction manual for proper installation methods and operation of air valve.

Instruction: After mat is installed open air valve by rotating valve "counter clockwise" 1 1/2 revolutions, let mat sit with valve open 30 seconds. Close valve by rotating clockwise.

Do not over-torque valve.

AVIS IMPORTANT

Lire le manuel d'utilisation pour connaître les méthodes correctes d'installation et de fonctionnement de la soupape pneumatique du tapis.

Mode d'emploi : une fois le tapis installé, ouvrir la soupape en la dévissant d'1 tour et dans le sens contraire aux aiguilles d'une montre, puis laisser reposer le tapis avec la soupape ouverte pendant 30 secondes. Refermer la soupape en la vissant dans le sens horaire. Ne pas serrer la soupape outre mesure.

AVVISO IMPORTANTE

Leggere il manuale di istruzioni in merito ai metodi di installazione ed al buon funzionamento della valvola dell'aria della pedana.

Istruzioni: dopo l'installazione della pedana, aprire la valvola dell'aria facendola ruotare in senso antiorario di 1 giro e 1/2. Lasciar riposare la pedana con la valvola aperta per 30 secondi.

Chiudere la valvola facendola ruotare in senso orario. Non serrare la valvola in modo eccessivo.

WICHTIGER HINWEIS

Anweisungen zu vorschriftsmäßigen Installationsverfahren und zum Betrieb des Mattenluftventils sind der Gebrauchsanweisung zu entnehmen.

Vorgehensweise: Nach Installation der Sicherheitsmatte das Luftventil durch eineinhalb Umdrehungen entgegen dem Uhrzeigersinn öffnen. Das Ventil 30 Sekunden lang geöffnet lassen.

Das Ventil durch Drehen im Uhrzeigersinn schließen. Ventil nicht zu stark anziehen.

AVISO IMPORTANTE

Lea en el manual de instrucciones los métodos de instalación y el funcionamiento apropiados de la válvula de aire de la alfombra.

Instrucciones: Una vez que se haya instalado la alfombra, abra la válvula de aire girándola "hacia la izquierda" 1 1/2 vueltas, y deje la alfombra en posición con la válvula abierta durante 30 segundos.

Cierre la válvula girándola hacia la derecha. No apriete la válvula excesivamente.

중요한 고지사항

매트 에어 밸브의 설치 방법과 작동에 대해서는 사용 안내서를 읽으십시오.

지시사항: 매트를 설치한 후에 밸브를 "시계 반대방향"으로 1½ 회전하여 에어 밸브를 열고, 밸브가 열린 상태에서 30초 동안 매트를 놔두십시오.

밸브를 시계 방향으로 회전하여 닫으십시오. 지나치게 힘을 가하여 밸브를 돌리지 마십시오.

注意

マットエアバルブの正しい取付および使用方法については取扱説明書をお読みください。

取扱指示: マットを取り付けた後、バルブを1-1.5回転「反時計方向」に回し、30秒間バルブを開いたままにして空気を抜きます。次にバルブを時計方向に回して閉じます。

バルブを余り強く回さないでください。

重要通告

请细读安全地毯手册上之气门按装程序以免有誤
按装程序: 当安全地毯按装好后还须平褥毯内气量才恰使用, 请先把气门螺丝钉轮转反时针方向后一个半圈, 请稍等三十秒后再把气门螺丝钉倒轮转紧闭。

切记: 勿用强力轮转紧闭

- Please refer to manual for detailed instruction on how to use the air valve.
- Consulter le manuel pour tous renseignements concernant le fonctionnement de la soupape pneumatique.
- Sírvase consultar el manual donde se detallan las instrucciones sobre cómo hacer funcionar la válvula de aire.
- Fare riferimento al manuale per istruzioni dettagliate in merito al funzionamento della valvola dell'aria.
- Ausführliche Hinweise zur Bedienung des Luftventils sind der entsprechenden Gebrauchsanweisung zu entnehmen.
- 에어 밸브 사용법에 대한 자세한 요령은 안내서를 참조하십시오.
- エアバルブの使い方についての詳細は、マニュアルを参照してください。
- 请细读安全地毯气门按装程序以免有誤



Label P/N 28607-0010 Rev.C

STI

Figure 7-9 Instruction for Air Equalization Valve

8 WARRANTY

8.1 OMRON STI PRODUCT WARRANTY INFORMATION

Omron STI warrants its products to be free from defects of material and workmanship and will, without charge, replace or repair any equipment found defective upon inspection at its factory, provided the equipment has been returned, transportation prepaid, within one year from date of installation and not to exceed 18 months from date of factory shipment.

The foregoing warranty is in lieu of and excludes all other warranties not expressly set forth herein, whether expressed or implied by operation of law or otherwise including but not limited to any implied warranties of merchantability or application for a particular purpose. No representation or warranty, express or implied, made by any sales representative, distributor, or other agent or representative of Omron STI which is not specifically set forth herein shall be binding upon Omron STI. Omron STI shall not be liable for any incidental or consequential damages, losses or expenses directly or indirectly arising from the sale, handling, improper application or use of the goods or from any other cause relating thereto and Omron STI's liability hereunder, in any case, is expressly limited to the repair or replacement (at Omron STI's option) of goods.

Warranty is authorized at the factory. Any on site service will be provided at the sole expense of the purchaser at standard field service rates.

All associated equipment must be protected by properly rated electronic/electrical protection devices. Omron STI shall not be liable for any damage due to improper engineering or installation by the purchaser or third parties. Proper installation, operation and maintenance of the product becomes the responsibility of the user upon receipt of the product.

Returns and allowances must be authorized by Omron STI in advance. Omron STI will assign a Returned Goods Authorization (RGA) number which must appear on all related papers and the outside of the shipping carton. All returns are subject to the final review by Omron STI. Returns are subject to restocking charges as determined by Omron STI.

WARNING! Any attempt to repair the Universal Safety Mat will void the warranty and may render the mat unsafe for use.

NOTE! This publication has been carefully checked for accuracy and is believed to be fully consistent with the products it describes. However, Omron STI does not assume liability for the contents of this publication; the examples used within or the use of any product described herein. Omron STI reserves the right to make changes to products and /or documentation without further notification.

Refer to Appendix A - European Norm EN 1760-1:1997, Annex B (Informative) for illustrations of proper vs. poor mat installation and recommendations to consider for all safety mat installations.

9 INSTALLATION EXAMPLE

9.1 EXAMPLE OF GOOD MAT INSTALLATION

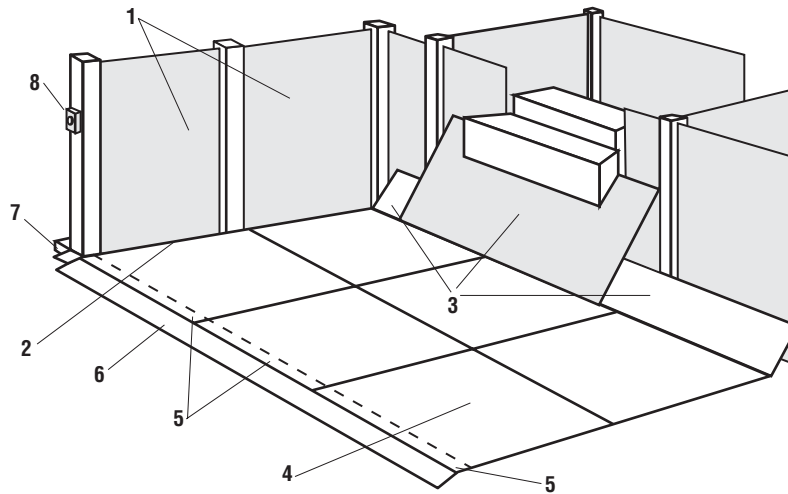

Figure 9-1 Good Mat Installation

1. Additional fixed guards are installed to prevent access to the danger zone of the machinery.
2. The fixed guard is arranged and designed in such a way that there is no access to the danger zone between the fixed guard and the safety mats. The fixed guard permits access to the danger zone through the sensors only.
3. A sloping cover plate prevents the operator standing at the side of the effective sensing field and in the danger zone.
4. Safety mats are properly installed.
5. The dead zones of the safety mats are located in such a way that the protective function will not be impaired.
6. The tripping hazard at the sensor edge is reduced by a ramp at the point of access. The ramp may also protect connecting cables.
7. Cable wireway is located outside the fixed guard. This prevents its misuse as an access to the hazard zone.
8. Reset button is located in a well protected location giving full visibility of the protected area.