



Mat Controller

MC3 Series

Installation and Operating Manual



OMRON Scientific Technologies Inc.
Manufacturing and Sales Office
6550 Dumbarton Circle
Fremont CA 94555-3605 USA

1 / 888 / 510-4357

Tel: 510/608-3400
Fax: 510/744-1442
www.sti.com



MC-3 Mat Controller

Table of Contents

Section 1—*Important safety message* page 4

Section 2—*Introduction* page 6

Section 3—*Description of Controls* page 6

Section 4—*Operating Mode* page 7

Section 5—*Installation* page 8

Section 6—*Machine Control Connections* page 11

Section 7—*Test Procedure* page 15

Section 8—*Trouble-shooting Faults* page 15

Section 9—*Specifications* page 16

Section 10—*Warranty and Additional Information* page 18

Section Appendix A —*Test Procedure* page 20



1 IMPORTANT SAFETY MESSAGE

A presence sensing mat and controller are general purpose presence sensing devices designed to guard personnel working around moving machinery. The use of this type of guarding system is regulated by government safety agencies.

Whether a specific machine application and presence sensing mat and controller installation complies with government regulations depends upon several items, including: the proper application, installation, maintenance and operation of the presence sensing mat and controller. These items are the sole responsibility of the purchaser, installer and employer.

The employer is also responsible for the selection and training of the personnel necessary to properly install, operate and maintain the machine and its safeguarding systems. For example, the presence sensing mat and controller should be installed, checked out and maintained only by a *qualified* person, defined as “*a person who, by possession of a recognized degree in applicable field or certificate of professional standing, or who by extensive knowledge, training, and experience, has successfully demonstrated the ability to solve problems relating to the subject matter and work.*” (ASME B30.2-2001)

The machine operator must notify management if the machine, tooling or safety devices are not operating properly. Never use the machine if it or the safety equipment is not in proper working order.

The following additional requirements must be met before using a safety mat and controller system:

- The machine on which the presence sensing mat and controller are installed must be capable of stopping motion anywhere in its cycle or stroke. Never use a presence sensing mat and controller on a power press with a full-revolution clutch.
- Do not use a presence sensing mat and controller:
 - on any device with inconsistent stopping time or inadequate control devices or mechanisms.
 - where the environment, such as corrosive chemicals, may degrade the performance of the mat and/or controller.
 - to initiate machine motion.



- When a presence sensing mat and controller are used as a safety device, the employer has the responsibility to ensure that all applicable federal, state, and local requirements, rules, codes and regulations are satisfied.
- All safety related machine control circuit elements, including pneumatic, electric or hydraulic controls, must be control reliable as defined by ANSI B11.19-2003, 6.1 which states in part:
 - prevent initiation of hazardous machine motion (or situation) until the failure is corrected or until the control system is manually reset; or
 - initiate an immediate stop command and prevent re-initiation of hazardous machine motion (or situation) until the failure is corrected or until the control system is manually reset; or
 - prevent re-initiation of hazardous machine motion (or situation) at the next normal stop command until the failure is corrected or until the control system is manually reset.
- All other machinery or equipment must meet OSHA standard 1910.212 for general machine guarding plus any other applicable regulations, codes and standards.
- Additional guarding such as safety light curtains or mechanical guards may be required if the presence sensing mat and controller do not protect all areas of entry to the point of operation hazard.
- All brakes and stopping mechanisms must be inspected regularly to ensure proper working order. If the stopping mechanisms are not working properly, the machine may not stop safely even though the presence sensing mat and controller are functioning properly.
- The Omron STI Test Procedure must be performed at installation and after any maintenance, modification or adjustment is performed on the machine controls or on the presence sensing mat and controller. The Test Procedure is presented in this manual.
- Do not perform any test or repairs other than those outlined in this manual. All electrical wiring must be installed in accordance with local electrical codes and regulations.
- The user must follow all procedures in this manual for proper operation of the MC3 controller.

The enforcement of these requirements is beyond Omron STI's control. The employer has the sole responsibility to follow the preceding requirements and any procedures, conditions and requirements specific to your machinery.

OMRON

2

2 INTRODUCTION

Presence sensing mats and the MC3 controller are used where perimeter access guarding is required, such as around robots, manufacturing work cells, food processing equipment and automated assembly equipment.

The MC3 controller is designed to meet the applicable sections of ANSI B11.19-2003, OSHA 1910.212, EN1760-1:1997 and ISO13856-1:2001. CE standards are met only when used in conjunction with STI UM series presence sensing safety mats.

The MC3 controller is designed to work in conjunction with a four-wire, normally open safety mat (such as the Omron STI UM series safety mats).

3

3 DESCRIPTION OF CONTROLS

3.1. OUTPUT RELAYS

The safety-rated outputs of the MC3 controller are referred to as Output Signal Switching Devices. (OSSD). When the mat surface is activated by sufficient weight, the OSSD will respond by going to an OFF state. Two-normally open OSSD are provided across terminal 13/14 and 23/24. Two normally closed OSSD are provided across terminals 31/32 and 41/42.

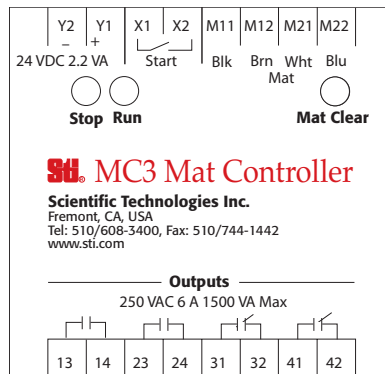

Figure 3-1 MC3 Mat Controller



3.2. INDICATORS

RUN: Will be lit when the OSSD relays are in the MACHINE RUN state.

STOP: Will be lit when the OSSD relays are in the MACHINE STOP state.

MAT CLEAR: A diagnostic indicator. Shows that the mat is properly wired, that it is clear, and that it is possible to energize the relays.

3.3. MAT INPUTS

Four terminal positions (M11-Blk, M12-Brn, M21-Blu, M22-Wh) are provided for input of a four-wire safety mat or a series of four-wire safety mats. See details in Section 5.2.—*Input Wiring.*

4 OPERATING MODE

4

4.1. AUTOMATIC RESTART

The MC3 controller will energize relays whenever the mat is clear, and de-energize whenever it has been stepped upon. During both power up and normal operation, an ON-delay of approximately 1/10 to 2/10 second is normal. The RUN indicator will follow the MAT CLEAR light.

4.2. START/RESTART INTERLOCK

The MC3 controller will interlock in de-energized state both upon application of power and also whenever the mat is stepped upon. Requires a manual reset operation to cause the system to energize relays. The MAT CLEAR light will indicate that it is possible to activate the start switch and enter into the MACHINE RUN state. The controller attempts to enter the RUN STATE upon the release of the start switch. Press and hold the start switch for more than 0.15 seconds. The safety mat area must be clear at the time the start switch is pressed and released.



OMRON

5

5 INSTALLATION

- ▲ WARNING!** Read this manual completely before installing the MC3 controller. The MC3 controller should only be installed, checked out, tested and maintained by a qualified person (as described in the Important Safety Message at the beginning of this manual). It is important that the user be familiar with the installation requirements, safe mounting distance, controls and features of the MC3 controller before using the guarding system.

5.1. MOUNTING

5.1.1 MODE SELECT

The installer must select whether the MC3 controller will operate in AUTOMATIC START or START/RESTART INTERLOCK mode. To make the selection, remove the terminal block on the input side of the controller box. Behind this terminal block are three yellow jumpers.

With all three jumpers installed, the controller is configured for AUTOMATIC START operation. This is the factory setting.

To configure for START/RESTART INTERLOCK operation, all three jumpers must be removed.

- ▲ WARNING!** *Perimeter Guarding Special Requirements: Perimeter guarding refers to installations where the presence sensing mats are positioned around the outside perimeter of the machine, robot or area to be guarded. This could leave sufficient space for an operator to stand between the mats and the machine.*

For perimeter guarding installations, the guarded machine or robot must be wired such that any interruption of the sensing area will cause an immediate stop of the hazardous motion. The machine or robot must only be restarted by actuation of a start switch. This start switch must be located outside the area of hazardous motion and positioned such that the hazardous area may be observed by the start switch operator.

Unexpected or automatic restart of the machine or robot may cause severe injury or death to the operator or other personnel.

Always contact the machine manufacturer for advice and assistance on the proper connection of any safety device.



5.1.2 ENCLOSURE

The MC3 controller is designed to be installed inside a machine control cabinet which has an environmental rating of at least IP54.

5.2. INPUT WIRING

5.2.1 POWER

A 24VDC power source is required. Connect PLUS to terminal block Y1 position and MINUS (0, Return) to terminal block Y2 position. (Note: see separate discussion of “earth”)

5.2.2 START

Used only in START/RESTART INTERLOCK mode. If AUTOMATIC START mode is used, no connection is required. If required, customer-supplied remote start switch with a single set of normally open contacts is used.

Two optional wiring configurations are acceptable:

- Connect the remote start switch between terminals X1 and X2.
- Connect one terminal of the remote start switch to +24VDC (must share a common return with MC3 power supply), and the second terminal to X2.

5.2.3 SAFETY MAT

An Omron STI 4-wire mat is expected. For an Omron STI Universal safety mat the blue and black conductors are connected to the bottom electrode plate. The brown and white conductors are connected to the top electrode plate. For a single mat installation, black is connected to M11 and blue to M21. The brown conductor is connected to M12 and white conductor is connected to M22.

Multiple mats must be connected to the controller in series. To wire an STI UM series multiple mat system in series, follow the wiring as shown in the drawing below:

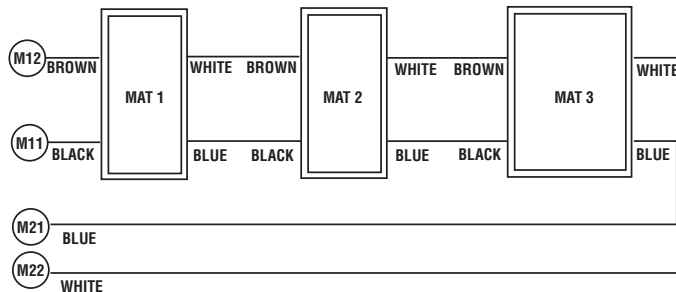

Figure 5-1 Hookup Drawing



- ▲ WARNING!** *Connecting mats in parallel will appear to work, but it is an UNSAFE installation. In this configuration, it is possible for one or more mats to be disconnected or have an open wire and the controller will not detect that these mats are non-functioning.*

5.2.4 EARTH CONSIDERATIONS

Normally, earthing of the house system is not a consideration. Presence sensing mats are sealed - any wiring to them should not be in contact with earth. Likewise, the mat controller operates between +24VDC and it's return, so the selection of an earth scheme is not significant.

However, there are abnormal conditions that could cause current flow due to house earth. This is related to the fact that mats lie on the floor, and are typically in close proximity to true "earth". Under certain conditions (e.g. wetting of the mat cable connectors), it is possible that one of the plates of the mat might become referenced to earth.

Note: *If the entire connector becomes immersed, this is the equivalent of the mat being shorted, and the system will simply indicate so, i.e. the mat clear indicator will not be able to light.*

One of the mat plates is electrically connected through the mat controller to the 24VDC return. (minus, Y2). If the plus side of the 24VDC power supply is earthed, and the minus side of the mat is also earthed, ground current will attempt to flow through the mat controller. This will cause the primary power fuse to blow. However, the fuse is a self-mending type, and will continue to re-make and blow again.

5.3. OUTPUT WIRING

Two safety outputs must be connected to, and operate, the two MPCE of the guarded machine. One to each. The product offers two normally closed and two normally open FSD (final switching device) outputs for this purpose. Customer shall wire by normal methods. External over-current protection must be provided by the user.

The remaining two connections may be used for indicator/communications purposes as desired.



6

6 MACHINE CONTROL CONNECTIONS

6.1. TWO NORMALLY OPEN PREFERRED CONNECTION METHOD

The following connection scheme uses both of the normally open output relay contacts to control the machine. This is the Omron STI recommended wiring method.

In the machine control circuit, locate the two machine primary control elements (MPCE1 & MPCE2). These are defined as *“The electrically powered element that directly controls the normal operation of a machine in such a way that it is the last element (in time) to function when machine operation is to be initiated or arrested.”* IEC 61496-1

The method to arrest hazardous machine motion will vary depending on the type of machine. Control methods include hydraulic, pneumatic, clutch and mechanical braking systems. For example, an MPCE may consist of relays, contactors, solenoids or electromechanical valves. If relays, the MPCE must use force-guided contact type relays.

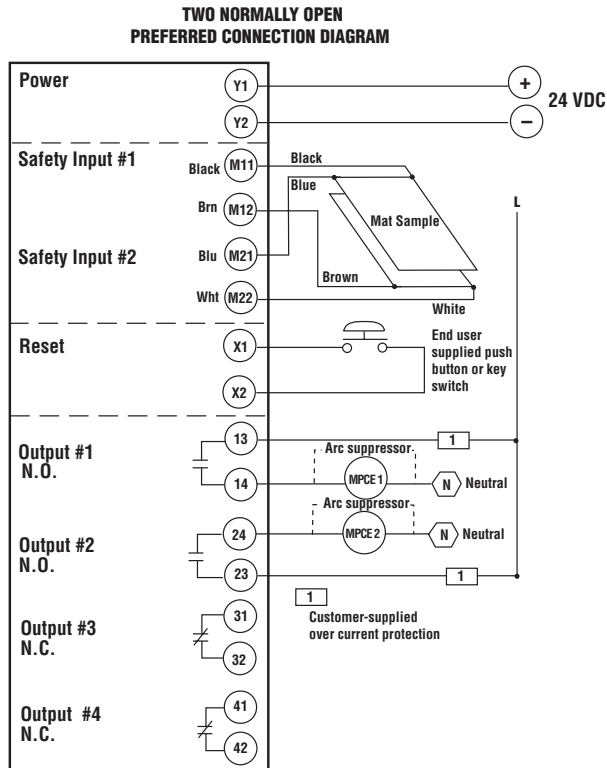

Figure 6-1 Two Normally Open Preferred Connection



6.2. SUGGESTED PLC CONNECTION

The wiring from the MC3 controller to the machine control must be control reliable as explained in ANSI B11.19-2003 section 6.1 or OSHA 1910.217(b)(13). Normally, PLCs are not designed to be control reliable and thus safety devices, such as safety mat systems, must not depend on a PLC to stop a guarded machine.

Figure 6-2 shows a connection diagram which provides for an extra set of contacts on each MPCE to be used as a signal input to a PLC. Note that in this diagram, the PLC is not wired directly to the MC3 controller and thus removes the PLC from the safety mat controller stop signal circuit.

Always contact the manufacturers of the PLC and the guarded machine before using a PLC in conjunction with an operator safety control.

The PLC control system design, wiring, installation and programming are the sole responsibility of the employer.

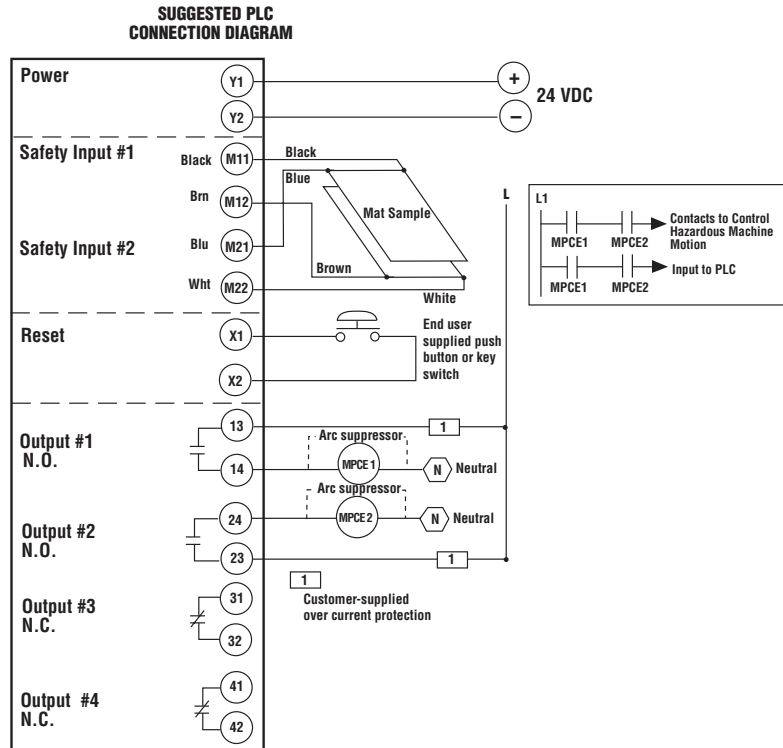

Figure 6-2 Suggested PLC Connection

- ⚠ WARNING!** To prevent severe injury to the operator or other personnel, **DO NOT** operate this presence sensing safety device (mat and controller system) unless it is properly installed, tested and inspected in accordance with all OSHA, ANSI, government, industry and company safety regulations. The guarded machine must be capable of stopping motion anywhere in its stroke or cycle. Do not use this safety device on a full revolution clutch machine.



7 TEST PROCEDURE

7.1. PERFORMING TEST PROCEDURE

The test procedure given in Appendix A must be performed by a qualified person at installation and after any maintenance, adjustment, or modification to the presence sensing mats, the MC3 controller or the machine and machine control circuitry. Testing ensures that the mats, MC3 controller, machine and machine control circuitry work properly to stop the machine. Failure to test properly could result in serious injury to personnel.

8 TROUBLE-SHOOTING FAULTS

8

Symptom

No indicators lit.

Possible Solutions

No power to the controller. Check 24VDC power supply and its connections to Y1/Y2. Also see earth discussion in Section 5.2.4 “Earth Considerations”.

Symptom

MAT CLEAR indicator cannot be made to light.

Possible Solutions

1. Mat wired improperly. Check connections.
2. Mat wire broken. Replace mat.
3. Mat is shorted. Is there something on the sensing area? Is the surface deformed?

Symptom

Cannot start in START/RESTART INTERLOCK mode.

Possible Solutions

1. Check wiring and operation of START switch. Is 24VDC being delivered when START is depressed and not delivered when it is released?
2. This line is internally fused with a self-mending fuse. Does it blow and reset repeatedly? If so, see earth discussion Section 5.2.4 “Earth Considerations”.

Symptom

All other conditions

Possible Solutions

Controller is defective. Replace. Call Omron STI for details.

9 SPECIFICATIONS

9

9.1. MAT CONTROLLER—MC3

9.1.1 GENERAL SPECIFICATIONS

Category: Category 3 safety device

Operating Modes: Automatic Start or Start/Restart Interlock

9.1.2 ELECTRICAL

Power Input: 24 VDC ($\pm 15\%$, < 3W.)

Safety Input: Connections for a four-wire mat system

Indicators: Green=Mat Clear; Green=Run; Red=Stop

Reset Function: User-supplied pushbutton or key switch

Safety Outputs: 2 NO and 2 NC outputs. 230VAC, 6A, 1500VA Maximum (non-fused)

Response time: < 0.030 seconds (STI UM series safety mat and controller combined)

9.1.3 CONSTRUCTION

Case Material: Polycarbonate

IP Rating: IP20

Mounting Type: 35mm DIN rail or screw mount to panel

Shipping Weight: 0.8 pounds (0.32 kg)

9.1.4 ENVIRONMENTAL

Temperature: 0° to +55°C (32° to 131°F)

Shock & Vibration: Per IEC 68-2-6, 0.15mm displacement, 10 to 55 Hz

Relative Humidity: 95%

9.1.5 STANDARDS CONFORMITY

Designed in Accordance with: EN1760-1:1997, EN954, ANSI/RIA 15.06-1999, ANSI B11.19-2003, OSHA 1910.212 & 1910.217(b)

9.2. SYSTEM DRAWINGS

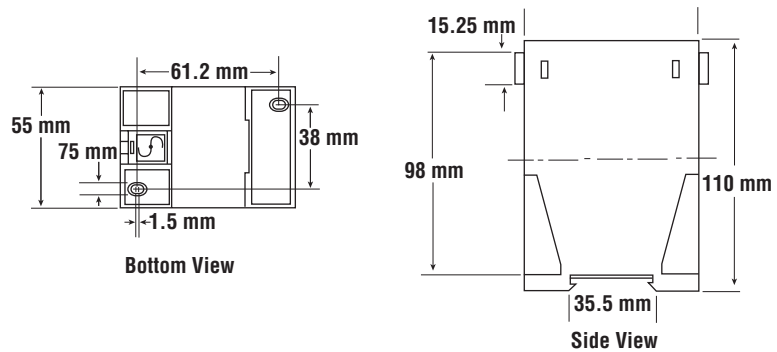

Figure 9-1 Mat Controller MC3 Dimensional Drawing



10 WARRANTY AND ADDITIONAL INFORMATION

10

10.1. OMRON STI WARRANTY

Omron STI warrants its products to be free from defects of material and workmanship and will, without charge, replace or repair any equipment found defective upon inspection at its factory, provided the equipment has been returned, transportation prepaid, within one year from the date of installation and not to exceed 18 months from date of factory shipment.

The foregoing warranty is in lieu of and excludes all other warranties not expressly set forth herein, whether expressed or implied by operation of law or otherwise including but not limited to any implied warranties of merchantability or fitness for a particular purpose. No representation or warranty, express or implied, made by any sales representative, distributor, or other agent or representative of Omron STI which is not specifically set forth herein shall be binding upon Omron STI. Omron STI shall not be liable for any incidental or consequential damages, losses or expenses directly or indirectly arising from the sale, handling, improper application or use of the goods or from any other cause relating thereto and Omron STI's liability hereunder, in any case, is expressly limited to repair or replacement (at Omron STI's option) of goods.

Warranty is specifically at the factory or an Omron STI authorized service location. Any on site service will be provided at the sole expense of the Purchaser at standard field service rates.

All associated equipment must be protected by properly rated electronic/electrical protection devices. Omron STI shall not be liable for any damage due to improper engineering or installation by the purchaser or third parties. Proper installation, operation and maintenance of the product becomes the responsibility of the user upon receipt of the product.

10.1.1 PATENTS

Elements of the electronics and optics essential to meet the specifications and performance standards of Omron STI controls are covered by one or more of the



following U.S. Patent Numbers: 3,774,039; 3,867,628; 3,967,111; 3,996,476; 4,007,387; 4,101,784; 5,015,840; Design 255,031, and other patents pending.

10.1.2 REPAIRS

Omron STI offers product repair service at our factory. If you need repairs made to any Omron STI product contact our Customer Service Department.

10.1.3 RETURNS

Whenever you return a product to Omron STI (even if the product is in warranty) please contact our Customer Service Department and request a Returned Goods Authorization number (RGA).

10.1.4 DOCUMENTATION CRITERIA

This publication has been carefully checked for accuracy and is believed to be fully consistent with the products it describes. However, Omron STI does not assume liability for the contents of this publication; the examples used within or the use of any product described herein. Omron STI reserves the right to make changes to products and/or documentation without further notification.



APPENDIX A — TEST PROCEDURE

A.1. TEST PROCEDURE LOG

The following test procedure must be performed by qualified personnel at installation and after any maintenance, adjustment or modification to the presence sensing mats, the MC3 controller or the machine and machine control circuitry. Testing ensures that the presense sensing mats, MC3 controller, machine and machine controll circuitry work properly to stop the machine. Failure to test properly could result in serious injury to personnel. Familiarity with this installation and operating manual is required before proceeding.

Item	Condition	Comments
1. With the machine power off, the MC3 controller power on and no pressure on the mat sensing area, verify that either a) a green RUN indicator is on, if set for AUTOMATIC START mode, or b) the red STOP indicator is on if set for START/RESTART INTERLOCK mode. In both cases the green MAT CLEAR indicator should be on.	<input type="checkbox"/> Pass <input type="checkbox"/> Fail	
2. If installed, press the START button to restart the controller from an interlocked state. The green RUN indicator should now be on and the output relays should be energized. The mat clear indicator should be on.	<input type="checkbox"/> Pass <input type="checkbox"/> Fail	
3. Step on the mat sensing area to activate the MC3 controller. The green RUN indicator should go off and, in all operating modes, the red STOP indicator should go on and the green MAT CLEAR indicator should go off. Repeat steps 2 and 3 for each mat in the sensing area.	<input type="checkbox"/> Pass <input type="checkbox"/> Fail	
4. With the MC3 controller in the RUN condition, start the machine to be guarded. Step on each mat in the sensing area and verify that the machine stops immediately and that the red STOP indicator illuminates.	<input type="checkbox"/> Pass <input type="checkbox"/> Fail	
5. If the presence sensing mats, MC3 controller or the machine fail any of these tests, DO NOT run the machine. Immediately tag or lockout the machine to prevent its use and notify the supervisor.	<input type="checkbox"/> Pass <input type="checkbox"/> Fail	

WARNING! To prevent severe injury to the operator or other personnel, DO NOT operate this presence sensing safety device unless it is properly installed, tested and inspected in accordance with all applicable ANSI, OSHA, government, industry and company safety regulations. The guarded machine must be capable of stopping motion anywhere in its cycle or stroke. Do not use this safety device on a full revolution clutch machine.